

MD10 XL

Weighing machine



The MD10 XL is a multihead weigher specially designed for large products such as potatoes, onions, beets and citrus fruits up to 15 cm. It is equipped with 10 extra-large weighing buckets and wide vibrating lanes for fast product flow. The MD10 XL has a weighing range of 2.5 to 50 kg and reaches speeds of up to 26 drops per minute with 10 kg weights.

Features

- Equipped with 10 extra large weighing buckets arranged in two opposing rows of 5.
- Can be delivered with feeding belts instead of vibrating lanes.
- Various discharge systems possible.
- Combinations with many packaging machines possible.
- Intuitive touchscreen interface for easy operation.

MD10 XL

Weighing machine

Specifications	Values
Weighing range	2.5 - 50 kg*
Capacity at 25kg up to	16 drops/min*
Capacity of the bucket	12 ltr
IP-rating	IP54
Air consumption (conditioned dry air)	125 L/min
Supply voltage	3×400V/50Hz/N/GND - 3×220V/60Hz/GND
Power consumption	4.9 kW
Weight of the machine	2050 kg

*Depending on product and discharge system.

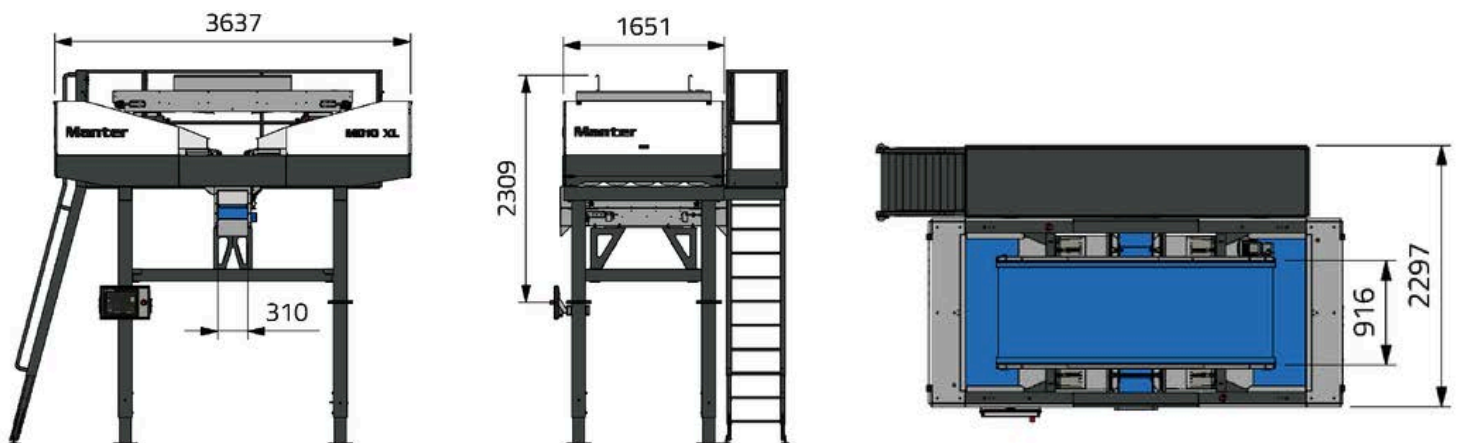

Manter International B.V.

Phileas Foggstraat 66
7825 AL Emmen
The Netherlands

Contact

+31 591 626300
sales@manter.com
www.manter.com



MD10 XL

Weegmachine



De MD10 XL is een combinatieveger die speciaal is ontworpen voor grote producten zoals aardappelen, uien, bieten en citrusvruchten tot 15 cm. De machine is uitgerust met 10 extra grote weegbakken en brede trilgoten voor een snelle productdoorstroming. De MD10 XL heeft een weegbereik van 2,5 tot 250kg en behaalt snelheden tot 26 stortingen per minuut bij een gewicht van 10kg.

Funcities

- Uitgerust met 10 extra grote weegbakken, opgesteld in twee tegenover elkaar liggende rijen van 5.
- Kan geleverd worden met toevoerbanden in plaats van trilgoten.
- Verschillende lossystemen mogelijk.
- Combinaties met vele verpakkingsmachines mogelijk.
- Intuïtieve touchscreeninterface voor eenvoudige bediening.

MD10 XL

Weegmachine

Specificaties	Waarden
Weegbereik	2.5 - 50 kg*
Capaciteit bij 25 kg tot	16 stortingen/min*
Inhoud van de weegbak	12 liter
IP-classificatie	IP54
Luchtverbruik (geconditioneerde droge lucht)	125 l/min
Voedingsspanning	3×400V/50Hz/N/GND - 3×220V/60Hz/GND
Stroomverbruik	4,9 kW
Gewicht van de machine	2050 kg

*Afhankelijk van het product en het afvoersysteem.

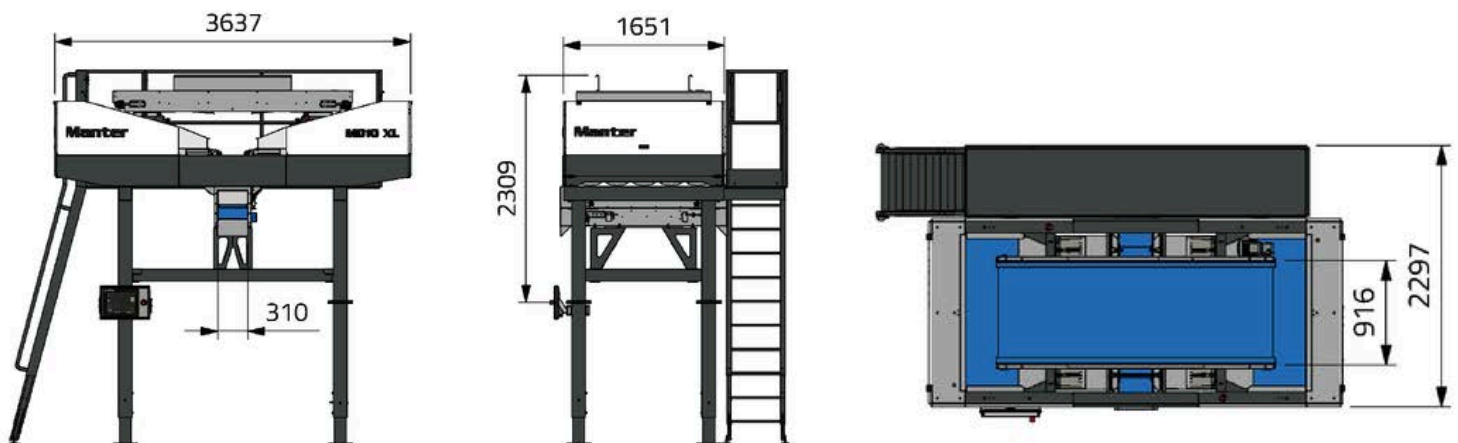

Manter International B.V.

Phileas Foggstraat 66
7825 AL Emmen
Nederland

Contact

+31 591 626300
sales@manter.com
www.manter.com



MD10 XL

Pesadoras



La MD10 XL es una pesadora multicabezal especialmente diseñada para productos grandes como patatas, cebollas, remolachas y cítricos de hasta 15cm. Está equipada con 10 cangilones extragrandes y carriles vibratorios anchos para un flujo rápido de producto. La MD10 XL tiene un rango de pesaje de 2,5 a 50kg y alcanza velocidades de hasta 26 descargas por minuto con pesos de 10kg.

Características

- Equipada con 10 cangilones extragrandes, distribuidos en dos filas opuestas de 5.
- Puede entregarse con cintas transportadoras en lugar de carriles vibratorios.
- Diversos sistemas de descarga posibles.
- Posibilidad de combinación con una amplia gama de máquinas de envasado.
- Interfaz de pantalla táctil intuitiva para un manejo sencillo.

MD10 XL

Pesadoras

Presupuesto	Valores
Rango de pesaje	2.5 - 50 kg*
Capacidad de hasta 25 kg	16 descargas/min*
Capacidad de los cangilones	12 litros
Clasificación IP	IP54
Consumo de aire (aire seco acondicionado)	125 L/min
Tensión de alimentación	3×400V/50Hz/N/GND - 3×220V/60Hz/GND
Consumo de energía	4,9 kW
Peso de la máquina	2050 kg

*Dependiendo del producto y sistema de descarga.

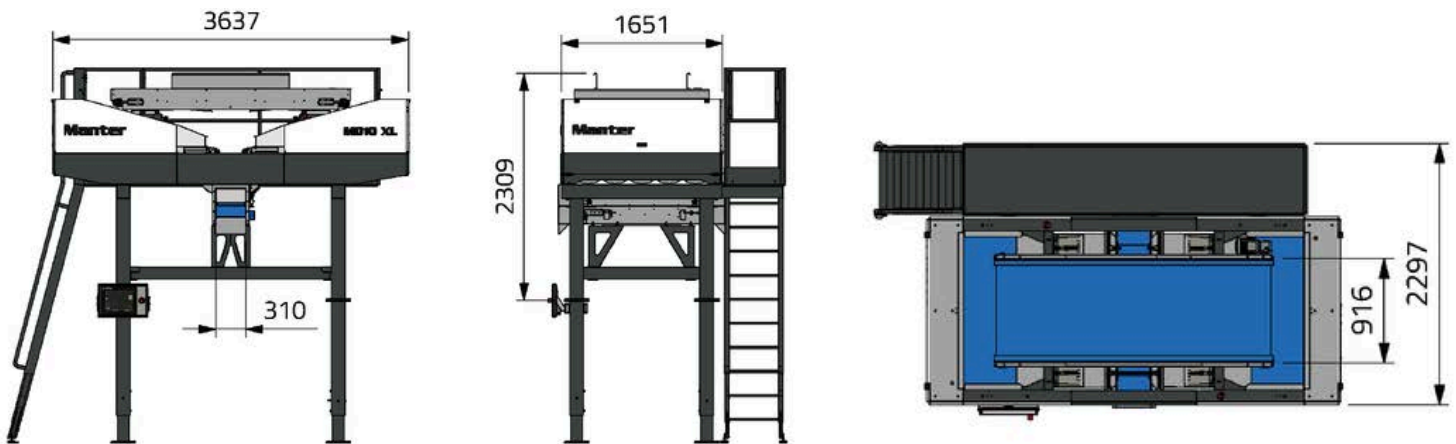

Manter International B.V.

Phileas Foggstraat 66
7825 AL Emmen
Países Bajos

Contacto

+31 591 626300
sales@manter.com
www.manter.com



MD10 XL

Waage



Die MD10 XL ist eine Mehrkopfwaage, die speziell für große Produkte wie Kartoffeln, Zwiebeln, Rüben und Zitrusfrüchte bis zu 15cm entwickelt wurde. Sie ist mit 10 extra großen Wiegebehältern und breiten Vibrationsrinnen für einen schnellen Produktfluss ausgestattet. Die MD10 XL bietet einen Wiegebereich von 2,5 bis 50kg und erreicht Geschwindigkeiten von bis zu 26 Abwürfen pro Minute bei 10kg Gewicht.

Merkmale

- Ausgestattet mit 10 extra großen Wiegebehältern, angeordnet in zwei gegenüberliegenden Reihen mit jeweils 5.
- Kann mit Zuführbändern statt Vibrationsrinnen geliefert werden.
- Verschiedene Austragssysteme möglich.
- Kombination mit vielen Verpackungsmaschinen möglich.
- Intuitive Touchscreen-Benutzeroberfläche für einfache Bedienung.

MD10 XL

Waage

Spezifikationen	Werte
Wägebereich	2.5 - 50 kg*
Kapazität bei 25 kg bis zu	16 Abwürfe/min*
Fassungsvermögen des Wiegekopfs	12 Liter
IP-Schutzart	IP54
Luftverbrauch (konditionierte Trockenluft)	125 l/min
Versorgungsspannung	3×400V/50Hz/N/GND - 3×220V/60Hz/GND
Stromverbrauch	4,9 kW
Gewicht der Maschine	2050 kg

*Abhängig vom Produkt und vom Entladesystem.

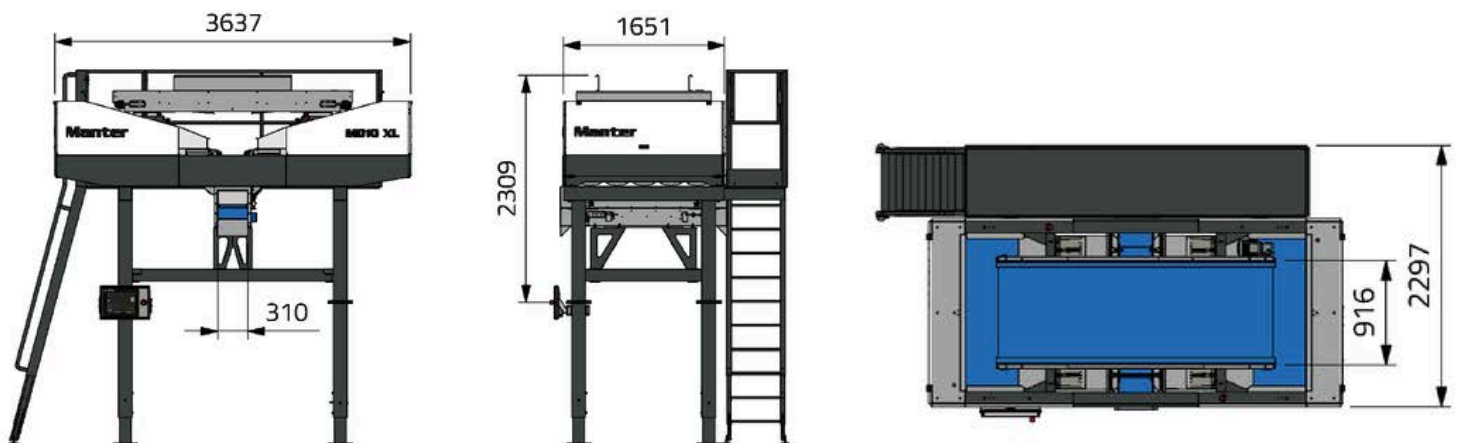

Manter International B.V.

Phileas Foggstraat 66
7825 AL Emmen
Niederlande

Kontakt

+31 591 626300
sales@manter.com
www.manter.com



MD10 XL

Peseuses



La MD10 XL est une peseuse associative spécialement conçue pour les produits volumineux tels que les pommes de terre, les oignons, les betteraves et les agrumes jusqu'à 15 cm. Elle est équipée de 10 godets de pesage extra-larges et de goulottes vibrantes larges pour un écoulement rapide des produits. La MD10 XL offre une plage de conditionnement de 2,5 à 50 kg et atteint des vitesses allant jusqu'à 26 déversements par minute avec des poids de 10 kg.

Caractéristiques

- Équipée de 10 godets de pesage extra-larges, disposés en deux rangées opposées de 5.
- Peut être livrée avec des bandes d'alimentation à la place des goulottes vibrantes.
- Différents systèmes de décharge possibles.
- Combinaison possible avec de nombreuses machines d'emballage.
- Interface écran tactile intuitive pour une utilisation facile.

MD10 XL

Peseuses

Caractéristiques

Valeurs

Plage de pesée	2.5 - 50 kg*
Capacité de 25 kg jusqu'à	16 déversements/min*
Capacité du godet	12 litres
Indice de protection IP	IP54
Consommation d'air (air sec conditionné)	125 L/min
Tension d'alimentation	3×400V/50Hz/N/GND - 3×220V/60Hz/GND
Consommation d'énergie	4,9 kW
Poids de la machine	2050 kg

*Selon le produit et le système de refolement.

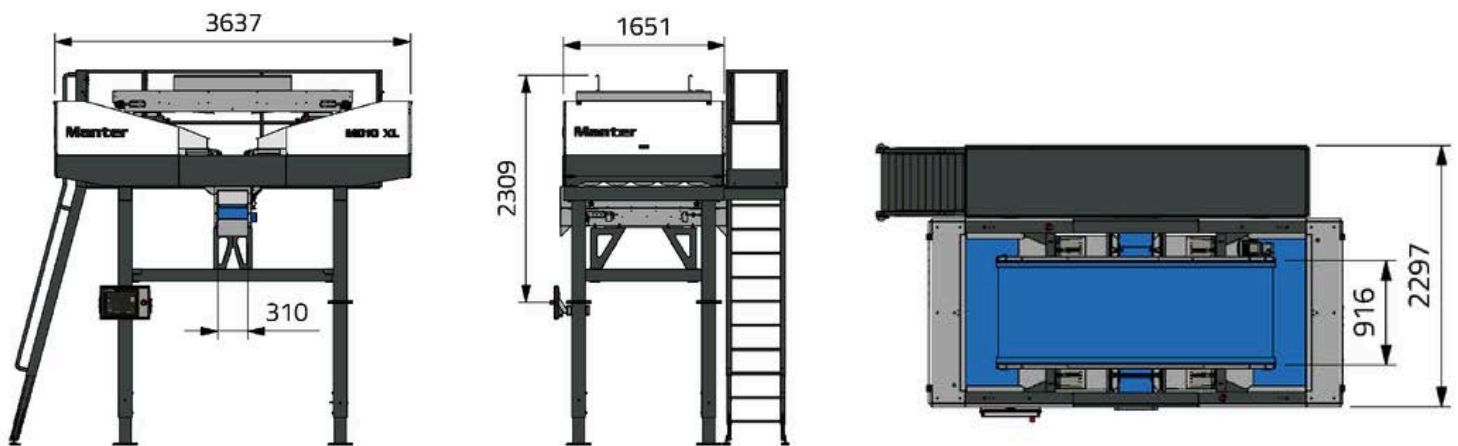

Manter International B.V.

Phileas Foggstraat 66
7825 AL Emmen
Pays-Bas

Contact

+31 591 626300
sales@manter.com
www.manter.com

