



M8

Weighing machine



The M8 is a compact multihead weigher with 8 weighing buckets, specifically designed for products such as potatoes, onions, and other fresh produce. As the smallest multihead weigher in our range, it is a compact and cost-efficient solution for accurate weighing of fresh produce. The M8 has a weighing range from 0.5 to 25 kg and achieves speeds of up to 35 drops per minute.

Features

- Equipped with 8 weighing buckets.
- Different discharge systems possible.
- Compatible with a wide range of packaging machines.
- Intuitive touchscreen interface for easy operation.



M8

Weighing machine

Specifications	Values
Weighing range	0.5 - 25 kg*
Capacity at 2.5kg up to	35 drops/min*
Capacity of the bucket	6 ltr
IP-rating	IP54
Air consumption (conditioned dry air)	100 L/min
Supply voltage	3×400V/50Hz/N/GND - 3×220V/60Hz/GND
Power consumption	3.4 kW
Weight of the machine	1250 kg

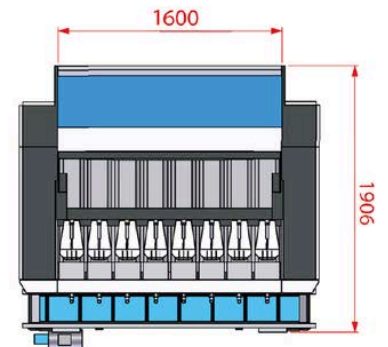
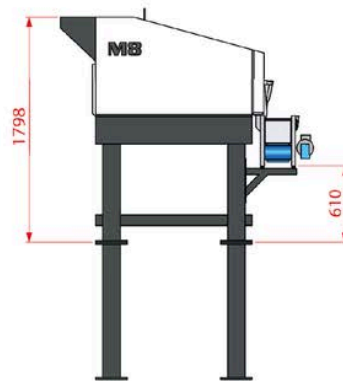
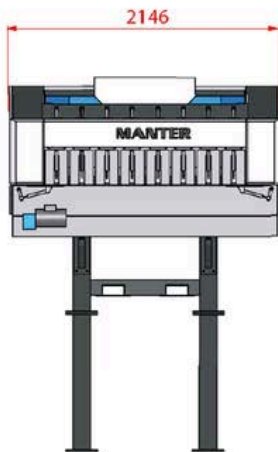

Manter International B.V.

Phileas Foggstraat 66
7825 AL Emmen
The Netherlands

Contact

+31 591 626300
sales@manter.com
www.manter.com





M8

Weegmachine



De M8 is een compacte combinatieweger met 8 weegbakken, speciaal ontworpen voor producten zoals aardappelen, uien en andere verse producten. Als kleinste combinatieweger in ons assortiment is dit een compacte en kostenefficiënte oplossing voor nauwkeurig wegen van AGF-producten. De M8 heeft een weegbereik van 0,5 tot 25 kg en bereikt snelheden tot 35 stortingen per minuut.

Funcities

- Uitgerust met 8 weegbakken.
- Verschillende lossystemen mogelijk.
- Compatibel met een breed scala aan verpakkingsmachines.
- Intuïtieve touchscreeninterface voor eenvoudige bediening.



M8

Weegmachine

Specificaties	Waarden
Weegbereik	0.5 - 25 kg*
Capaciteit bij 2,5 kg tot	35 stortingen/min*
Inhoud van de weegbak	6 liter
IP-classificatie	IP54
Luchtverbruik (geconditioneerde droge lucht)	100 l/min
Voedingsspanning	3x400V/50Hz/N/GND - 3x220V/60Hz/GND
Stroomverbruik	3,4 kW
Gewicht van de machine	1250 kg

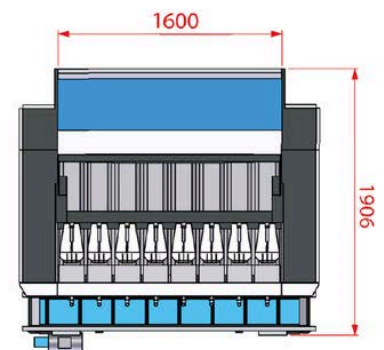
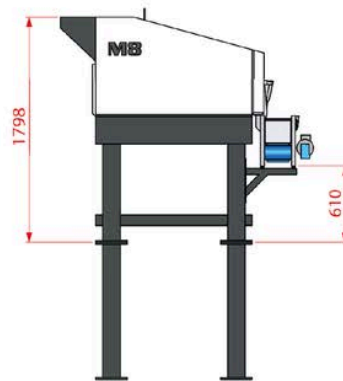
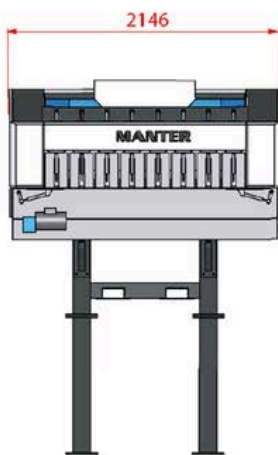

Manter International B.V.

Phileas Foggstraat 66
7825 AL Emmen
Nederland

Contact

+31 591 626300
sales@manter.com
www.manter.com





M8

Pesadoras



La M8 es una pesadora multicabezal compacta con 8 cangilones de pesaje, especialmente diseñada para productos como patatas, cebollas y otros productos frescos. Como la pesadora multicabezal más pequeña de nuestra gama, es una solución compacta y rentable para el pesaje preciso de productos frescos. La M8 tiene un rango de pesaje de 0,5 a 25 kg y alcanza velocidades de hasta 35 descargas por minuto.

Características

- Equipada con 8 cangilones de pesaje.
- Diversos sistemas de descarga disponibles.
- Compatible con una amplia gama de máquinas de envasado.
- Interfaz de pantalla táctil intuitiva para un manejo sencillo.



M8

Pesadoras

Presupuesto	Valores
Rango de pesaje	0.5 - 25 kg*
Capacidad de 2,5 kg hasta	35 descargas/min*
Capacidad de los cangilones	6 litros
Clasificación IP	IP54
Consumo de aire (aire seco acondicionado)	100 L/min
Tensión de alimentación	3x400V/50Hz/N/GND - 3x220V/60Hz/GND
Consumo de energía	3,4 kW
Peso de la máquina	1250 kg

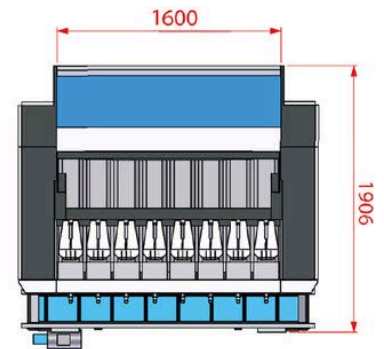
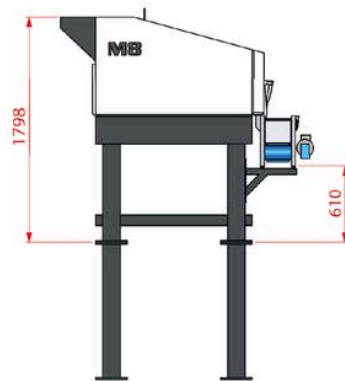
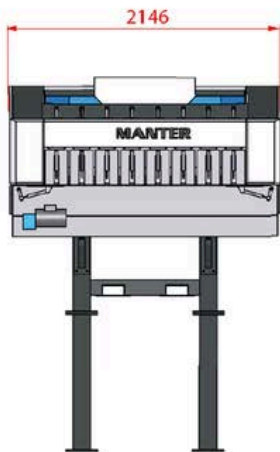

Manter International B.V.

Phileas Foggstraat 66
7825 AL Emmen
Países Bajos

Contacto

+31 591 626300
sales@manter.com
www.manter.com





M8

Waage



Die M8 ist eine kompakte Mehrkopfwage mit 8 Wiegebehältern, die speziell für Produkte wie Kartoffeln, Zwiebeln und andere Frischprodukte entwickelt wurde. Als kleinste Mehrkopfwage in unserem Sortiment ist sie eine kompakte und kosteneffiziente Lösung für das präzise Wiegen von Frischprodukten. Die M8 hat einen Wägebereich von 0,5 bis 25 kg und erreicht Geschwindigkeiten von bis zu 35 Abwürfen pro Minute.

Merkmale

- Ausgestattet mit 8 Wiegebehältern.
- Verschiedene Austragssysteme möglich.
- Kompatibel mit einer Vielzahl von Verpackungsmaschinen.
- Intuitive Touchscreen-Benutzeroberfläche für einfache Bedienung.



M8

Waage

Spezifikationen	Werte
Wägebereich	0.5 - 25 kg*
Kapazität bei 2,5 kg bis zu	35 Abwürfe/Min*
Fassungsvermögen des Wiegekopfs	6 Liter
IP-Schutzart	IP54
Luftverbrauch (konditionierte Trockenluft)	100 l/min
Versorgungsspannung	3x400V/50Hz/N/GND - 3x220V/60Hz/GND
Stromverbrauch	3,4 kW
Gewicht der Maschine	1250 kg

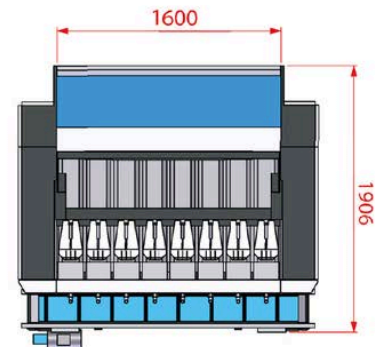
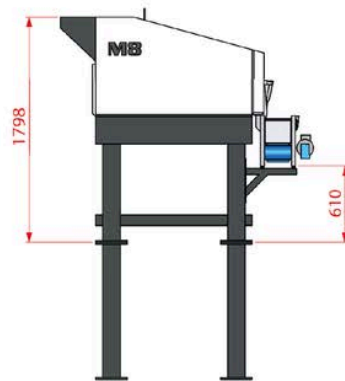
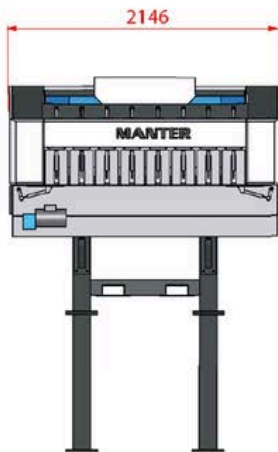

Manter International B.V.

Phileas Foggstraat 66
7825 AL Emmen
Niederlande

Kontakt

+31 591 626300
sales@manter.com
www.manter.com



M8

Peseuses



La M8 est une peseuse associative compacte équipée de 8 godets de pesage, spécialement conçue pour des produits tels que les pommes de terre, les oignons et autres produits frais. En tant que plus petite peseuse associative de notre gamme, elle constitue une solution compacte et économique pour un pesage précis des produits frais. La M8 dispose d'une plage de pesage de 0,5 à 25 kg et atteint des vitesses allant jusqu'à 35 décharges par minute.

Caractéristiques

- Équipée de 8 godets de pesage.
- Différents systèmes de décharge possibles.
- Compatible avec une large gamme de machines d'emballage.
- Interface écran tactile intuitive pour une utilisation facile.



M8

Peseuses

Caractéristiques	Valeurs
Plage de pesée	0.5 - 25 kg*
Capacité de 2,5 kg jusqu'à	35 déversements/min*
Capacité du godet	6 litres
Indice de protection IP	IP54
Consommation d'air (air sec conditionné)	100 L/min
Tension d'alimentation	3x400V/50Hz/N/GND - 3x220V/60Hz/GND
Consommation d'énergie	3,4 kW
Poids de la machine	1250 kg

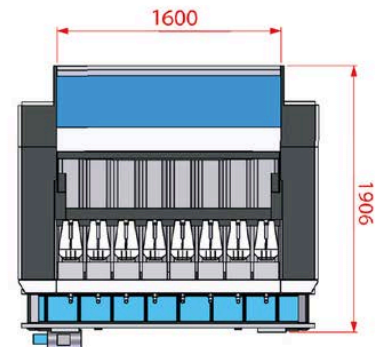
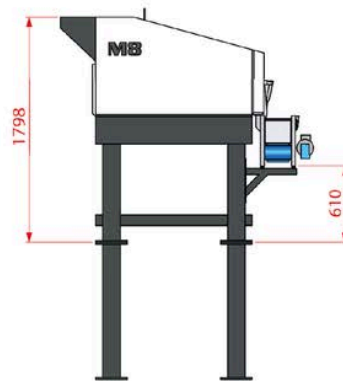
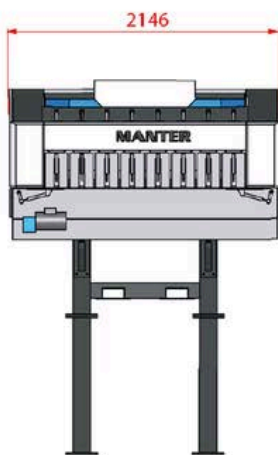

Manter International B.V.

Phileas Foggstraat 66
7825 AL Emmen
Pays-Bas

Contact

+31 591 626300
sales@manter.com
www.manter.com

