

M2 XXL

Weighing machine



The M2 XXL is a simple and robust linear weigher, specially designed for products such as potatoes and onions. It is primarily intended for weights between 5 and 25kg per bucket, with higher weights possible in multi-drop mode. Three lanes of varying widths fill the bucket quickly, and as the target weight is approached, only the narrow lane adds the final portion to ensure accurate weighing. The M2 XXL can achieve a capacity of up to 14 drops per minute at 25kg.

Features

- Linear weigher equipped with two large weighing buckets, suitable for weights between 5 and 50 kg.
- Each weighing bucket is equipped with three vibrating lanes for efficient filling.
- Various discharge systems available.
- Compatible with a wide range of packaging machines.
- Intuitive touchscreen interface for easy operation.

M2 XXL

Weighing machine

Specifications	Values
Weighing range	5 - 50 kg*
Capacity at 2.5kg up to	14 storingen/min*
Capacity of the bucket	46 liter
IP-rating	IP54
Air consumption (conditioned dry air)	100 l/min
Supply voltage	3×400V/50Hz/N/GND - 3×220V/60Hz/GND
Power consumption	3,6 kW
Weight of the machine	1050 kg

*Depending on product and discharge system.

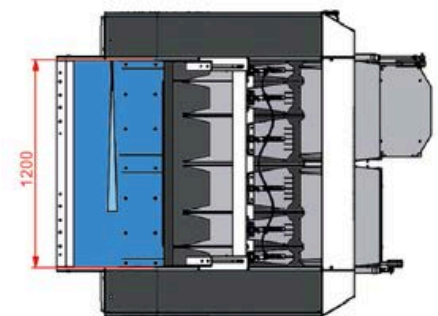
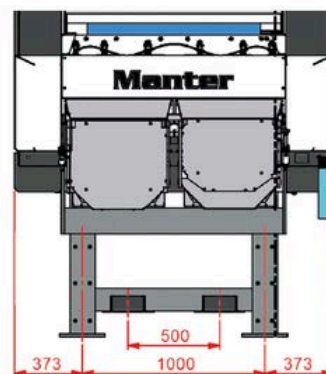
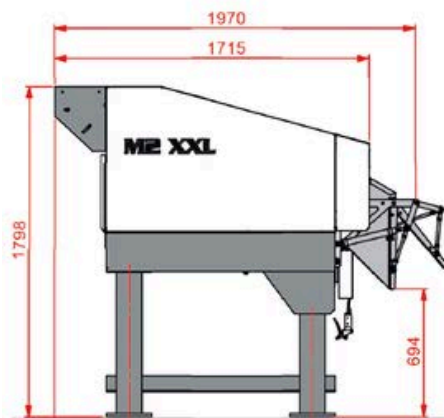

Manter International B.V.

Phileas Foggstraat 66
7825 AL Emmen
The Netherlands

Contact

+31 591 626300
sales@manter.com
www.manter.com



M2 XXL

Weegmachine



De M2 XXL is een eenvoudige en robuuste lineaire weger, speciaal ontworpen voor producten zoals aardappelen en uien. Hij is voornamelijk bedoeld voor gewichten tussen 5 en 25 kg per bak, waarbij hogere gewichten mogelijk zijn in multi-dropmodus. Drie banen van verschillende breedtes vullen de bak snel, en wanneer het streefgewicht wordt bereikt, voegt alleen de smalle baan de laatste hoeveelheid toe om nauwkeurig wegen te garanderen. De M2 XXL kan een capaciteit van maximaal 14 stortingen per minuut bij 25 kg behalen.

Funcities

- Lineaire weger uitgerust met twee grote weegbakken, geschikt voor gewichten tussen 5 en 50 kg.
- Elke weegbak voorzien van drie trilbanen voor efficiënte vulling.
- Verschillende lossingsystemen beschikbaar.
- Compatibel met een breed scala aan verpakkingsmachines.
- Intuïtieve touchscreeninterface voor eenvoudige bediening.

M2 XXL

Weegmachine

Specificaties	Waarden
Weegbereik	5 - 50 kg*
Capaciteit bij 25 kg tot	14 stortingen/min*
Inhoud van de weegbak	46 liter
IP-classificatie	IP54
Luchtverbruik (geconditioneerde droge lucht)	100 l/min
Voedingsspanning	3×400V/50Hz/N/GND - 3×220V/60Hz/GND
Stroomverbruik	3,6 kW
Gewicht van de machine	1050 kg

*Afhankelijk van het product en het afvoersysteem.

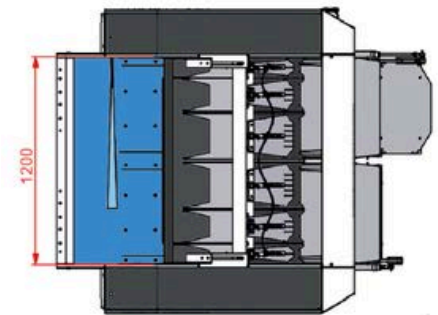
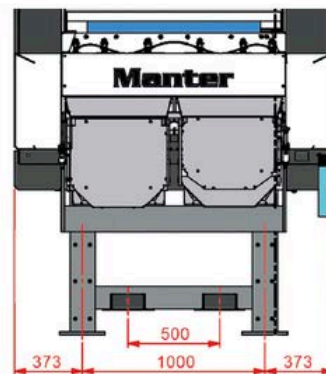
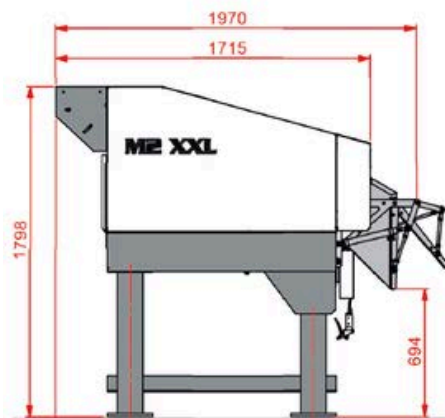

Manter International B.V.

Phileas Foggstraat 66
7825 AL Emmen
Nederland

Contact

+31 591 626300
sales@manter.com
www.manter.com





M2 XXL

Pesadoras



La M2 XXL es una pesada lineal simple y robusta, especialmente diseñada para productos como patatas y cebollas. Está principalmente destinada a pesos entre 5 y 25 kg por cangilón, siendo posibles pesos mayores en modo multi-descarga. Tres carriles de diferentes anchos llenan rápidamente el cangilón, y al acercarse al peso objetivo, solo el carril estrecho añade la porción final para garantizar un pesaje preciso. La M2 XXL puede alcanzar una capacidad de hasta 14 descargas por minuto a 25 kg.

Características

- Pesadora lineal equipada con dos cangilones grandes, adecuada para pesos entre 5 y 50 kg.
- Cada cangilón cuenta con tres carriles vibratorios para un llenado eficiente.
- Diversos sistemas de descarga disponibles.
- Compatible con una amplia gama de máquinas de envasado.
- Interfaz de pantalla táctil intuitiva para un manejo sencillo.



M2 XXL

Pesadoras

Presupuesto

Valores

Rango de pesaje	5 - 50 kg*
Capacidad de hasta 25 kg	14 descargas/min*
Capacidad de los cangilones	46 litros
Clasificación IP	IP54
Consumo de aire (aire seco acondicionado)	100 L/min
Tensión de alimentación	3×400V/50Hz/N/GND - 3×220V/60Hz/GND
Consumo de energía	3,6 kW
Peso de la máquina	1050 kg

*Dependiendo del producto y sistema de descarga.

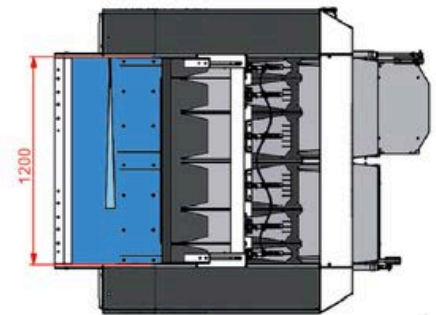
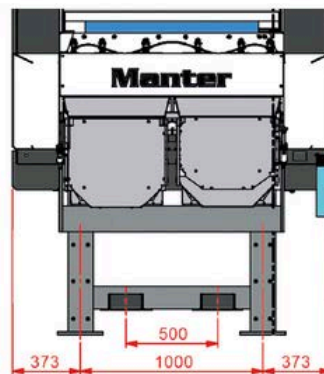
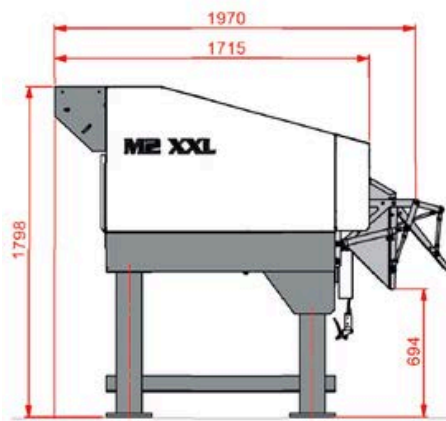

Manter International B.V.

Phileas Foggstraat 66
7825 AL Emmen
Países Bajos

Contacto

+31 591 626300
sales@manter.com
www.manter.com





M2 XXL

Waage



Die M2 XXL ist eine einfache und robuste Linealwaage, speziell für Produkte wie Kartoffeln und Zwiebeln entwickelt. Sie ist hauptsächlich für Gewichte zwischen 5 und 25 kg pro Behälter vorgesehen, wobei höhere Gewichte im Multi-Drop-Modus möglich sind. Drei Bahnen unterschiedlicher Breite füllen den Behälter schnell, und wenn das Zielgewicht erreicht wird, fügt nur die schmale Bahn die letzte Portion hinzu, um präzises Wiegen zu gewährleisten. Die M2 XXL erreicht eine Kapazität von bis zu 14 Abwürfen pro Minute bei 25 kg.

Merkmale

- Linealwaage ausgestattet mit zwei großen Wiegebehältern, geeignet für Gewichte zwischen 5 und 50 kg.
- Jeder Wiegebehälter mit drei Vibrationsbahnen für effizientes Befüllen.
- Verschiedene Austragsysteme verfügbar.
- Kompatibel mit einer Vielzahl von Verpackungsmaschinen.
- Intuitive Touchscreen-Benutzeroberfläche für einfache Bedienung.



M2 XXL

Waage

Spezifikationen

Werte

Wägebereich	5 - 50 kg*
Kapazität bei 25 kg bis zu	14 Abwürfe/min*
Fassungsvermögen des Wiegekopfs	46 Liter
IP-Schutzart	IP54
Luftverbrauch (konditionierte Trockenluft)	100 l/min
Versorgungsspannung	3 x 400 V/50 Hz/N/GND – 3 x 220 V/60 Hz/GND
Stromverbrauch	3,6 kW
Gewicht der Maschine	1050 kg

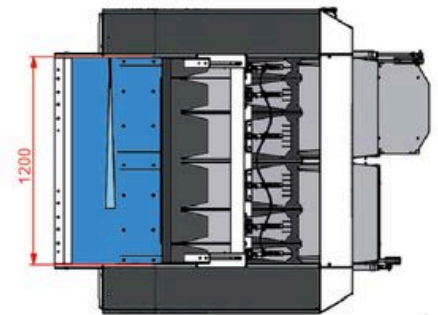
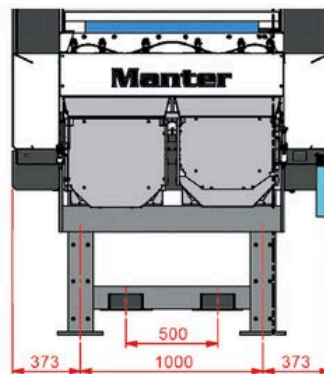
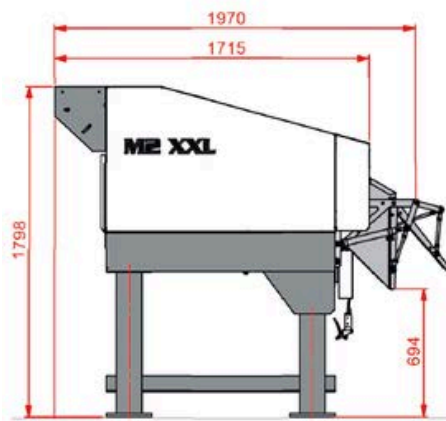

Manter International B.V.

Phileas Foggstraat 66
7825 AL Emmen
Niederlande

Kontakt

+31 591 626300
sales@manter.com
www.manter.com



M2 XXL

Peseuses



La M2 XXL est une peseuse linéaire simple et robuste, spécialement conçue pour des produits tels que les pommes de terre et les oignons. Elle est principalement conçue pour des poids compris entre 5 et 25 kg par godet, avec des poids supérieurs possibles en mode multi-déversement. Trois voies de largeurs différentes remplissent rapidement le godet, et à l'approche du poids cible, seule la voie étroite ajoute la portion finale pour garantir un pesage précis. La M2 XXL peut atteindre une capacité de jusqu'à 14 déversements par minute à 25 kg.

Caractéristiques

- Peseuse linéaire équipée de deux godets de pesage larges, adaptée aux poids entre 5 et 50 kg.
- Chaque godet est doté de trois voies vibrantes pour un remplissage efficace.
- Différents systèmes de décharge possibles.
- Compatible avec une large gamme de machines d'emballage.
- Interface écran tactile intuitive pour une utilisation facile.

M2 XXL

Peseuses

Caractéristiques

Valeurs

Plage de pesée	5 - 50 kg*
Capacité de 25 kg jusqu'à	14 déversements/min*
Capacité du godet	46 litres
Indice de protection IP	IP54
Consommation d'air (air sec conditionné)	100 L/min
Tension d'alimentation	3×400V/50Hz/N/GND - 3×220V/60Hz/GND
Consommation d'énergie	3,6 kW
Poids de la machine	1050 kg

*Selon le produit et le système de refolement.

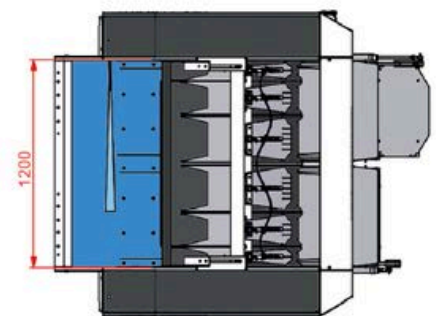
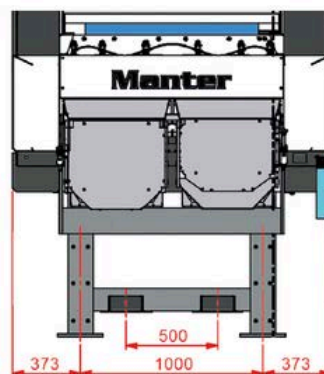
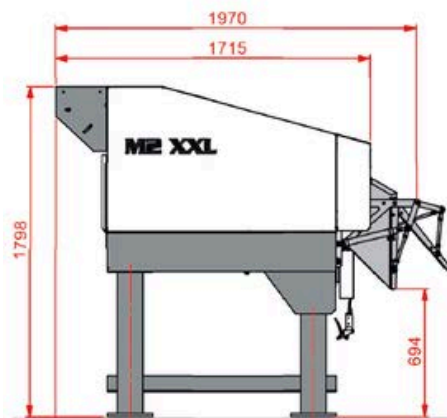

Manter International B.V.

Phileas Foggstraat 66
7825 AL Emmen
Pays-Bas

Contact

+31 591 626300
sales@manter.com
www.manter.com

