

M16i Fr

Weighing machine

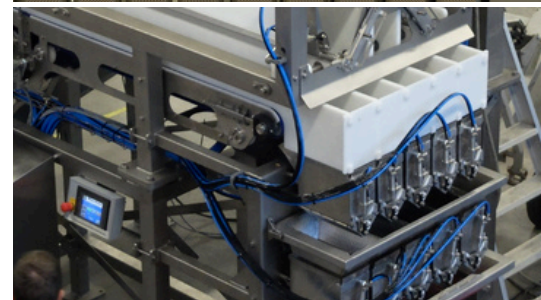
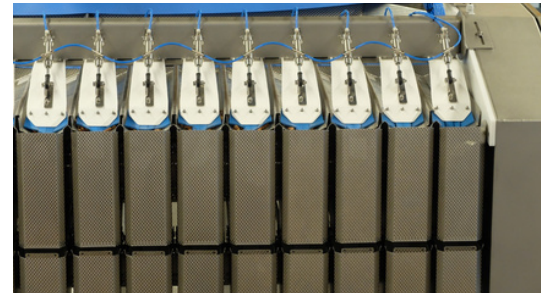

The M16i Fr is a stainless steel multihead weigher specifically designed for the frozen food industry, combining high speed with optimal hygiene. It is ideal for processors weighing individually quick frozen (IQF) products, whole fish, meat, or poultry. Equipped with 16 buckets, the M16i Fr is optimized for high-capacity applications with small to medium weight ranges. Both the dosing and weighing buckets are removable, ensuring easy and thorough cleaning. The M16i Fr offers a weighing range from 250 g to 2.5 kg and can achieve speeds of up to 80 drops per minute.

Features

- Equipped with 16 weighing and dosing buckets inline for high speed and accuracy.
- Suitable for accurate weighing of fresh products and deep-frozen IQF foods, including frozen fish, meat, and vegetables.
- Non-stick patterned sheet metal for improved product flow.
- Multiple discharge configurations available.
- Compatible with a wide range of packaging machines.
- Intuitive touchscreen interface for easy operation.

M16i Fr

Weighing machine

Specifications	Values
Weighing range	0.25 - 2.5 kg*
Capacity at 2.5kg up to	80 drops/min*
Capacity of the bucket	6 ltr
IP-rating	IP65
Air consumption (conditioned dry air)	150 L/min
Supply voltage	3×400V/50Hz/N/GND - 3×220V/60Hz/GND
Power consumption	5.5 kW
Weight of the machine	2700 kg

*Depending on product and discharge system.

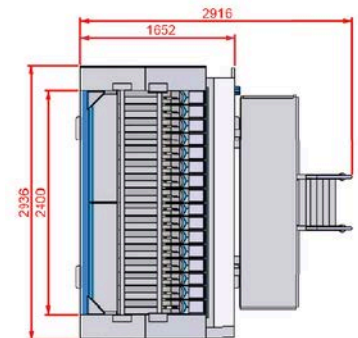
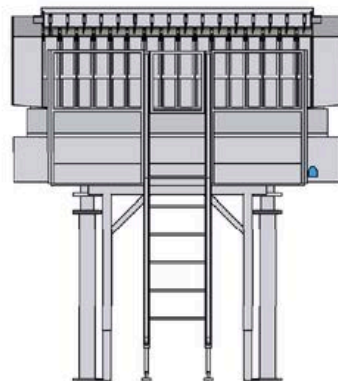
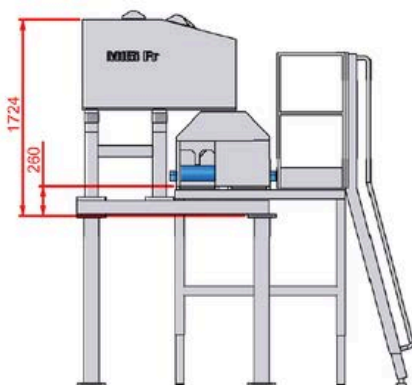

Manter International B.V.

Phileas Foggstraat 66
7825 AL Emmen
The Netherlands

Contact

+31 591 626300
sales@manter.com
www.manter.com



M16i Fr

Weegmachine

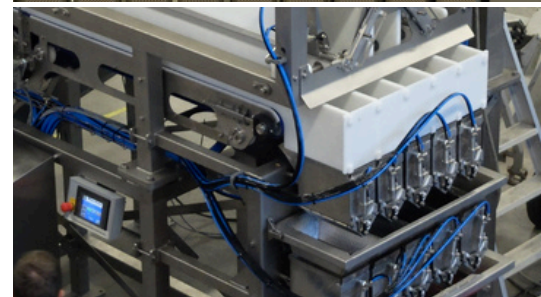
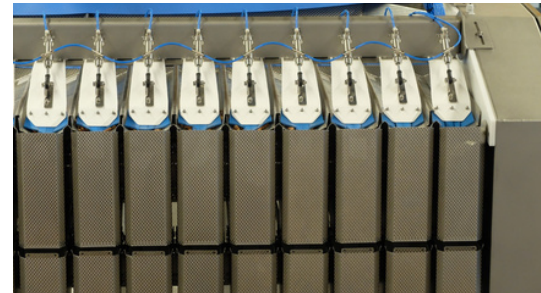

De M16i Fr is een combinatieveger van roestvrij staal, speciaal ontworpen voor de diepvriesindustrie, waarbij hoge snelheid en optimale hygiëne worden gecombineerd. Ideaal voor verwerkers van individueel ingevroren producten (IQF), hele vis, vlees en gevogelte. Uitgerust met 16 weegbakken, is de M16i Fr geoptimaliseerd voor toepassingen met hoge capaciteit bij kleine tot middelgrote gewichten. Zowel de doseer- als de weegbakken zijn verwijderbaar, wat gemakkelijk en grondig reinigen mogelijk maakt. De M16i Fr biedt een weegbereik van 250g tot 2,5kg en kan snelheden tot 80 stortingen per minuut bereiken.

Funcities

- Uitgerust met 16 weeg- en doseerbakken in lijn voor hoge snelheid en nauwkeurigheid.
- Geschikt voor nauwkeurig wegen van verse producten en diepgevroren IQF-voeding, inclusief vis, vlees en groenten.
- Non-stick patroon op het metaal voor verbeterde productdoorstroming.
- Meerdere lossingsconfiguraties mogelijk.
- Compatibel met een breed scala aan verpakkingsmachines.
- Intuïtieve touchscreeninterface voor eenvoudige bediening.

M16i Fr

Weegmachine

Specificaties	Waarden
Weegbereik	0.25 - 2.5 kg*
Capaciteit bij 2,5 kg tot	80 stortingen/min*
Inhoud van de weegbak	6 liter
IP-classificatie	IP65
Luchtverbruik (geconditioneerde droge lucht)	150 l/min
Voedingsspanning	3x400V/50Hz/N/GND - 3x220V/60Hz/GND
Stroomverbruik	5,5 kW
Gewicht van de machine	2700 kg

*Afhankelijk van het product en het afvoersysteem.

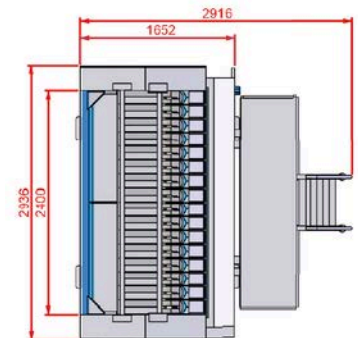
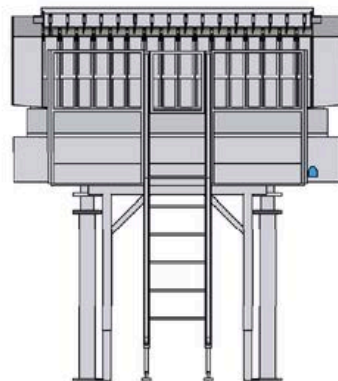
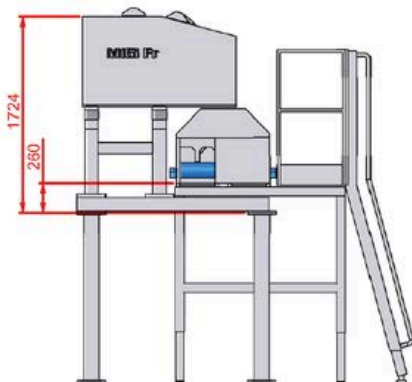

Manter International B.V.

Phileas Foggstraat 66
7825 AL Emmen
Nederland

Contact

+31 591 626300
sales@manter.com
www.manter.com



M16i Fr

Pesadoras

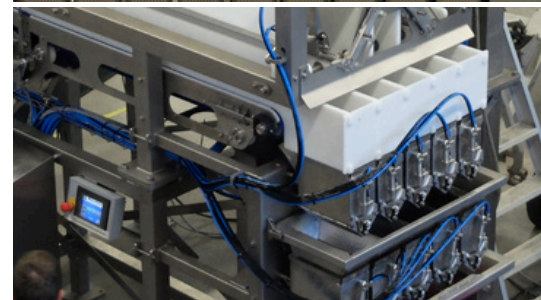
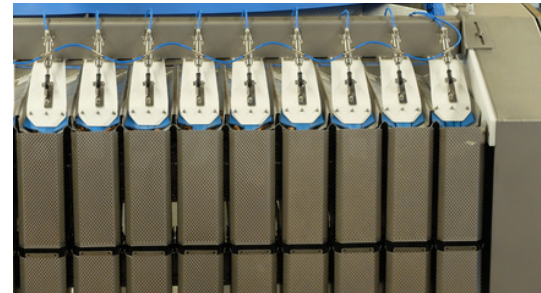

La M16i Fr es una pesada multicabezal de acero inoxidable, diseñada específicamente para la industria de alimentos congelados, combinando alta velocidad con higiene óptima. Ideal para procesadores de productos congelados individualmente (IQF), pescado entero, carne y aves. Equipada con 16 cangilones, la M16i Fr está optimizada para aplicaciones de alta capacidad con rangos de peso pequeños a medianos. Tanto los cangilones de dosificación como los de pesaje son extraíbles, lo que permite una limpieza fácil y completa. La M16i Fr ofrece un rango de pesaje de 250g a 2,5kg y puede alcanzar hasta 80 descargas por minuto.

Características

- Equipada con 16 cangilones de pesaje y dosificación en línea para alta velocidad y precisión.
- Adecuada para un pesaje preciso de productos frescos y alimentos congelados IQF, incluyendo pescado, carne y verduras.
- Chapa metálica con patrón antiadherente para mejorar el flujo del producto.
- Múltiples configuraciones de descarga disponibles.
- Compatible con una amplia gama de máquinas de envasado.
- Interfaz de pantalla táctil intuitiva para un manejo sencillo.

M16i Fr

Pesadoras

Presupuesto	Valores
Rango de pesaje	0.25 - 2.5 kg*
Capacidad de 2,5 kg hasta	80 descargas/min*
Capacidad de los cangilones	6 litros
Clasificación IP	IP65
Consumo de aire (aire seco acondicionado)	150 L/min
Tensión de alimentación	3x400V/50Hz/N/GND - 3x220V/60Hz/GND
Consumo de energía	5,5 kW
Peso de la máquina	2700 kg

*Dependiendo del producto y sistema de descarga.

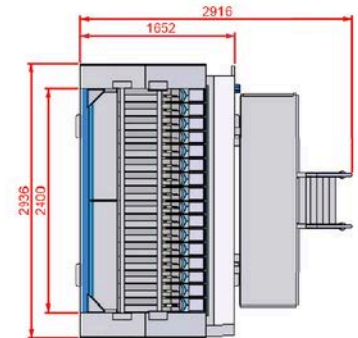
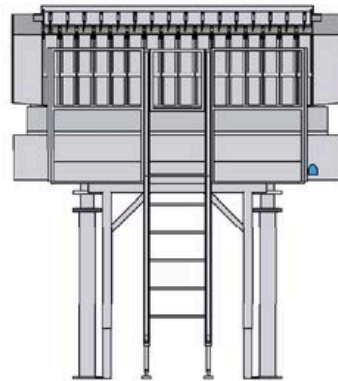
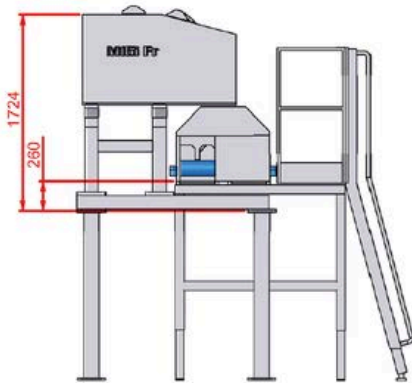

Manter International B.V.

Phileas Foggstraat 66
7825 AL Emmen
Países Bajos

Contacto

+31 591 626300
sales@manter.com
www.manter.com



M16i Fr

Waage

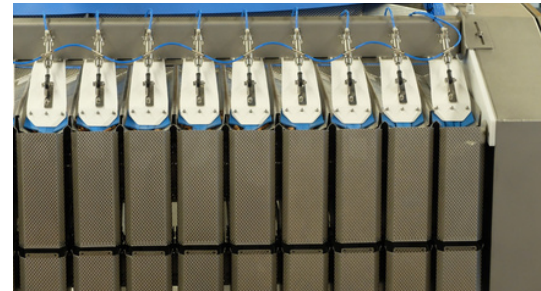

Die M16i Fr ist eine Mehrkopfwage aus Edelstahl, speziell für die Tiefkühlkostindustrie entwickelt, und verbindet hohe Geschwindigkeit mit optimaler Hygiene. Ideal für Verarbeiter von einzeln schockgefrosteten Produkten (IQF), ganzer Fisch, Fleisch und Geflügel. Ausgestattet mit 16 Wiegebehältern, ist die M16i Fr für hochkapazitive Anwendungen bei kleinen bis mittleren Gewichtsbereichen optimiert. Sowohl die Dosier- als auch die Wiegebehälter sind abnehmbar, was eine einfache und gründliche Reinigung ermöglicht. Die M16i Fr bietet einen Wiegebereich von 250g bis 2,5kg und erreicht Geschwindigkeiten von bis zu 80 Abwürfen pro Minute.

Merkmale

- Ausgestattet mit 16 Wiege- und Dosierbehältern in Linie für hohe Geschwindigkeit und Genauigkeit.
- Geeignet für das präzise Wiegen von frischen Produkten und tiefgefrorenen IQF-Lebensmitteln, einschließlich Fisch, Fleisch und Gemüse.
- Antihaft-Muster auf dem Metall für verbesserten Produktfluss.
- Mehrere Austragskonfigurationen möglich.
- Kompatibel mit einer Vielzahl von Verpackungsmaschinen.
- Intuitive Touchscreen-Benutzeroberfläche für einfache Bedienung.

M16i Fr

Waage

Spezifikationen	Werte
Wägebereich	0.25 - 2.5 kg*
Kapazität bei 2,5 kg bis zu	80 Abwürfe/Min*
Fassungsvermögen des Wiegekopfs	6 Liter
IP-Schutzart	IP65
Luftverbrauch (konditionierte Trockenluft)	150 l/min
Versorgungsspannung	3x400V/50Hz/N/GND - 3x220V/60Hz/GND
Stromverbrauch	5,5 kW
Gewicht der Maschine	2700 kg

*Abhängig vom Produkt und vom Entladesystem.

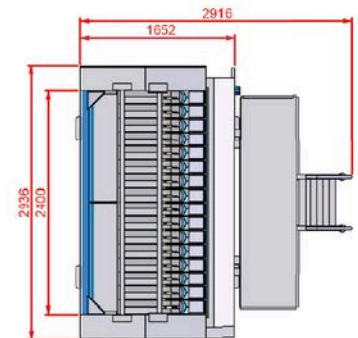
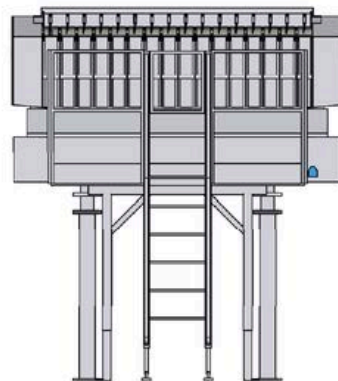
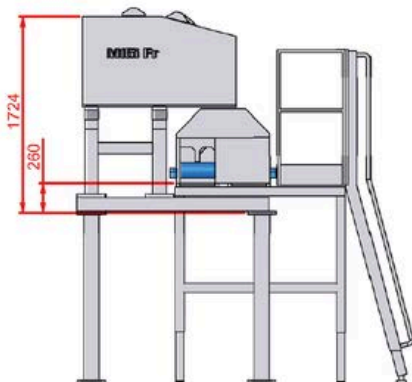

Manter International B.V.

Phileas Foggstraat 66
7825 AL Emmen
Niederlande

Kontakt

+31 591 626300
sales@manter.com
www.manter.com



M16i Fr

Peseuses

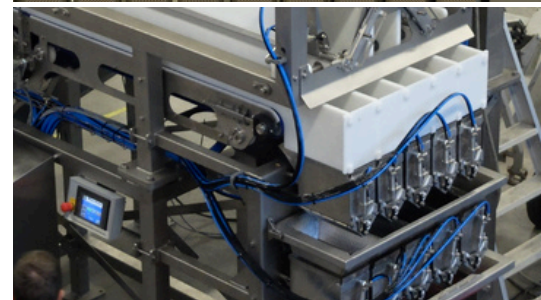
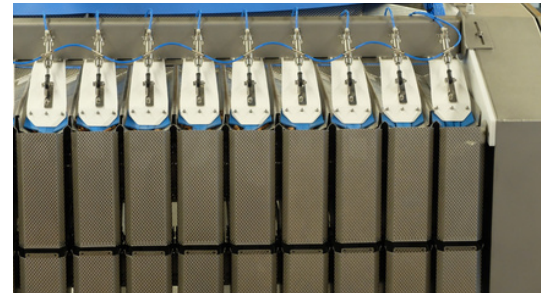

La M16i Fr est une peseuse associative en acier inoxydable, spécialement conçue pour l'industrie des aliments surgelés, combinant haute vitesse et hygiène optimale. Idéale pour les transformateurs de produits individuellement congelés (IQF), poissons entiers, viande et volaille. Équipée de 16 godets, la M16i Fr est optimisée pour les applications à haute capacité avec des plages de poids petites à moyennes. Les godets de pesage et de dosage sont amovibles, permettant un nettoyage facile et complet. La M16i Fr offre une plage de pesage de 250 g à 2,5 kg et peut atteindre jusqu'à 80 déversements par minute.

Caractéristiques

- Équipée de 16 godets de pesage et de dosage en ligne pour une grande vitesse et précision.
- Convient pour le pesage précis de produits frais et d'aliments surgelés IQF, y compris poisson, viande et légumes.
- Tôle avec motif antiadhésif pour améliorer l'écoulement du produit.
- Différentes configurations de décharge possibles.
- Compatible avec une large gamme de machines d'emballage.
- Interface écran tactile intuitive pour une utilisation facile.

M16i Fr

Peseuses

Caractéristiques	Valeurs
Plage de pesée	0.25 - 2.5 kg*
Capacité de 2,5 kg jusqu'à	80 déversements/min*
Capacité du godet	6 litres
Indice de protection IP	IP65
Consommation d'air (air sec conditionné)	150 L/min
Tension d'alimentation	3×400V/50Hz/N/GND - 3×220V/60Hz/GND
Consommation d'énergie	5,5 kW
Poids de la machine	2700 kg

*Selon le produit et le système de refolement.

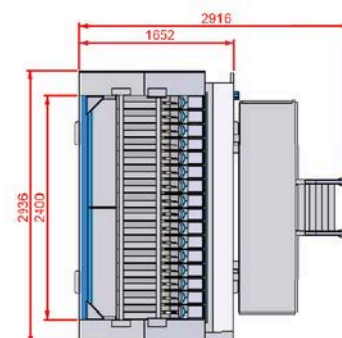
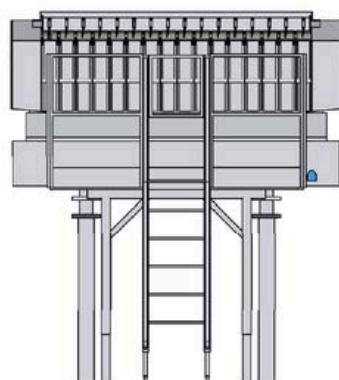
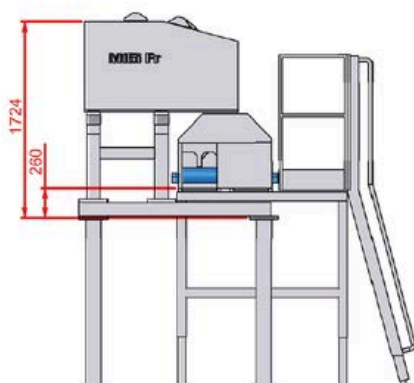

Manter International B.V.

Phileas Foggstraat 66
7825 AL Emmen
Pays-Bas

Contact

+31 591 626300
sales@manter.com
www.manter.com

