

M12i V

Weighing machine



The M12i V is a stainless steel multihead weigher, specially designed for products such as cherries and cherry tomatoes. It features V-shaped weighing buckets that open on both sides onto a double discharge belt, ensuring high capacity. Thanks to the low drop height, the product is placed directly onto the discharge belt for gentle handling. The M12i V offers a weighing range from 250g to 2.5kg and can achieve speeds of up to 55 drops per minute.

Features

- Equipped with 12 weighing and dosing buckets inline.
- Minimal product drop height due to V-shaped weighing buckets.
- Combinations with many packaging machines possible.
- Intuitive touchscreen interface for easy operation.

M12i V

Weighing machine

Specifications	Values
Weighing range	0.25 - 5 kg*
Capacity at 1kg up to	50 drops/min*
Capacity of the bucket	3.2 ltr
IP-rating	IP54 or IP65
Air consumption (conditioned dry air)	150 L/min
Supply voltage	3×400V/50Hz/N/GND - 3×220V/60Hz/GND
Power consumption	4.6 kW
Weight of the machine	1450 kg

*Depending on product and discharge system.

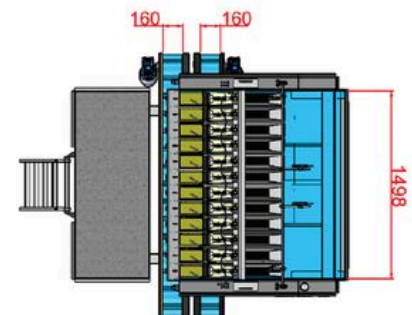
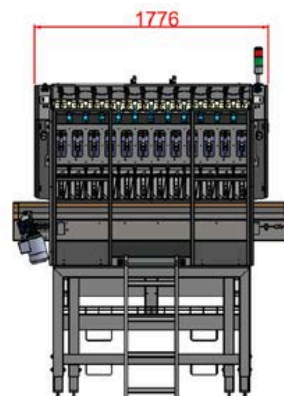
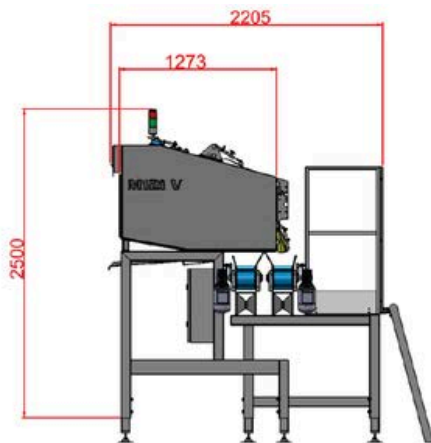

Manter International B.V.

Phileas Foggstraat 66
7825 AL Emmen
The Netherlands

Contact

+31 591 626300
sales@manter.com
www.manter.com



M12i V

Weegmachine



De M12i V is een combinatieveger van roestvrij staal, speciaal ontworpen voor producten als kersen en cherrytomaten. Hij is uitgerust met V-vormige weegbakken die aan beide zijden openen op een dubbele afvoerband, wat zorgt voor een hoge capaciteit. Dankzij de lage valhoogte wordt het product direct op de afvoerband geplaatst, waardoor het zacht wordt behandeld. Het weegbereik van de M12i V loopt van 250g tot 2,5kg, met snelheden tot 55 stortingen per minuut.

Funcities

- Uitgerust met 12 weeg- en doseerbakken in lijn.
- Minimale productvalhoogte dankzij V-vormige weegbakken.
- Combinaties met een breed scala aan verpakkingsmachines mogelijk.
- Intuïtieve touchscreeninterface voor eenvoudige bediening.

M12i V

Weegmachine

Specificaties	Waarden
Weegbereik	0,25 - 5 kg*
Capaciteit bij 1 kg tot	50 stortingen/min*
Inhoud van de weegbak	3,2 liter
IP-classificatie	IP54 of IP65
Luchtverbruik (geconditioneerde droge lucht)	150 l/min
Voedingsspanning	3×400V/50Hz/N/GND - 3×220V/60Hz/GND
Stroomverbruik	4,6 kW
Gewicht van de machine	1450 kg

*Afhankelijk van het product en het afvoersysteem.

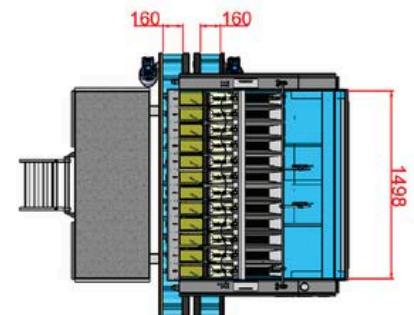
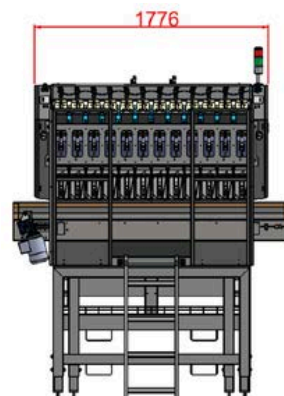
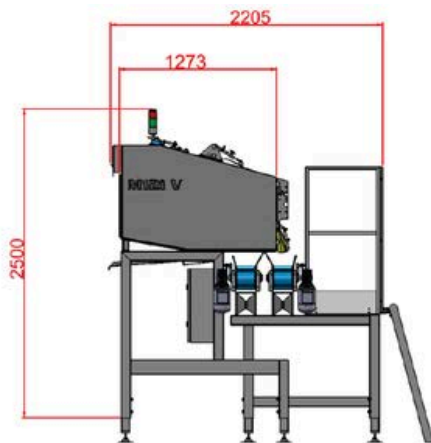

Manter International B.V.

Phileas Foggstraat 66
7825 AL Emmen
Nederland

Contact

+31 591 626300
sales@manter.com
www.manter.com



M12i V

Pesadoras



La M12i V es una pesadora multicabezal de acero inoxidable, especialmente diseñada para productos como cerezas y tomates cherry, equipada con cangilones de pesaje en forma de V que se abren por ambos lados sobre una cinta de descarga doble para garantizar una alta capacidad; gracias a la baja altura de caída, el producto se deposita directamente sobre la cinta de descarga para un manejo delicado, y la M12i V ofrece un rango de pesaje de 250 g a 2,5 kg alcanzando velocidades de hasta 55 descargas por minuto.

Características

- Equipada con 12 cangilones de pesaje y dosificación en línea.
- Altura mínima de caída del producto gracias a los cangilones en forma de V.
- Posibilidad de combinación con una amplia gama de máquinas de envasado.
- Interfaz de pantalla táctil intuitiva para un manejo sencillo.

M12i V

Pesadoras

Presupuesto	Valores
Rango de pesaje	0,25 - 5 kg*
Capacidad de 1 kg hasta	50 descargas/min*
Capacidad de los cangilones	3,2 litros
Clasificación IP	IP54 o IP65
Consumo de aire (aire seco acondicionado)	150 L/min
Tensión de alimentación	3×400V/50Hz/N/GND - 3×220V/60Hz/GND
Consumo de energía	4,6 kW
Peso de la máquina	1450 kg

*Dependiendo del producto y sistema de descarga.

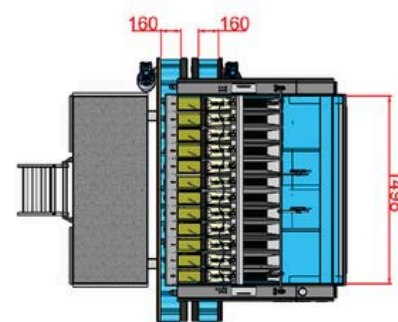
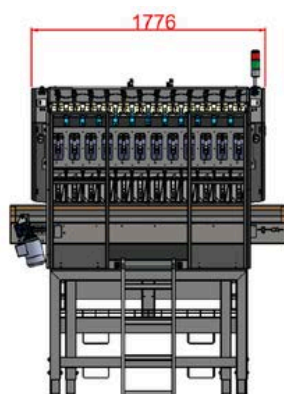
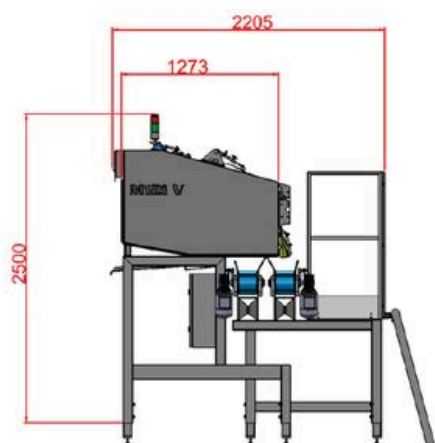

Manter International B.V.

Phileas Foggstraat 66
7825 AL Emmen
Países Bajos

Contacto

+31 591 626300
sales@manter.com
www.manter.com



M12i V

Waage



Die M12i V ist eine Mehrkopfwage aus Edelstahl, die speziell für Produkte wie Kirschen und Cherrytomaten entwickelt wurde und mit V-förmigen Wiegebehältern ausgestattet ist, die sich beidseitig auf ein Doppelabfuhrband öffnen und so eine hohe Kapazität gewährleisten; dank der geringen Fallhöhe wird das Produkt direkt auf das Abfuhrband abgelegt, was eine schonende Handhabung ermöglicht, und die M12i V bietet einen Wägebereich von 250 g bis 2,5 kg bei Geschwindigkeiten von bis zu 55 Abwürfen pro Minute.

Merkmale

- Ausgestattet mit 12 Wiege- und Dosierbehältern in Linie.
- Minimale Produktfallhöhe dank V-förmiger Wiegebehälter.
- Kombination mit einer Vielzahl von Verpackungsmaschinen möglich.
- Intuitive Touchscreen-Benutzeroberfläche für einfache Bedienung.

M12i V

Waage

Spezifikationen	Werte
Wägebereich	0,25 - 5 kg*
Kapazität bei 1 kg bis zu	50 Abwürfe/Min*
Fassungsvermögen des Wiegekopfs	3,2 Liter
IP-Schutzart	IP54 oder IP65
Luftverbrauch (konditionierte Trockenluft)	150 l/min
Versorgungsspannung	3×400V/50Hz/N/GND - 3×220V/60Hz/GND
Stromverbrauch	4,6 kW
Gewicht der Maschine	1450 kg

*Abhängig vom Produkt und vom Entladesystem.

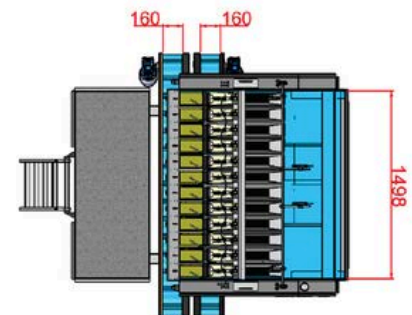
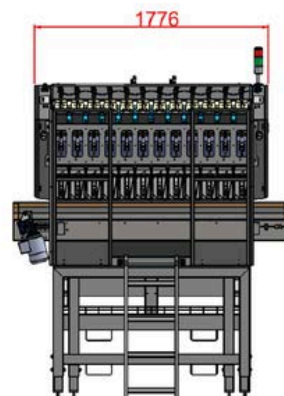
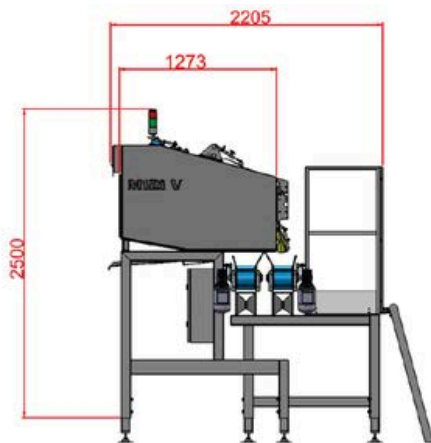

Manter International B.V.

Phileas Foggstraat 66
7825 AL Emmen
Niederlande

Kontakt

+31 591 626300
sales@manter.com
www.manter.com



M12i V

Peseuses



La M12i V est une peseuse associative en acier inoxydable spécialement conçue pour des produits tels que les cerises et les tomates cerises, équipée de bennes de pesage en forme de V qui s'ouvrent des deux côtés sur un convoyeur de décharge double afin de garantir une capacité élevée ; grâce à la faible hauteur de chute, le produit est déposé directement sur le convoyeur de décharge pour une manipulation en douceur, et la M12i V offre une plage de pesage de 250 g à 2,5 kg avec des vitesses allant jusqu'à 55 déversements par minute.

Caractéristiques

- Équipée de 12 godets de pesage et de dosage en ligne.
- Hauteur de chute minimale du produit grâce aux godets en forme de V.
- Combinaison possible avec une large gamme de machines d'emballage.
- Interface écran tactile intuitive pour une utilisation facile.

M12i V

Peseuses

Caractéristiques	Valeurs
Plage de pesée	0,25 - 5 kg*
Capacité à 1 kg jusqu'à	50 déversements/min*
Capacité du godet	3,2 litres
Indice de protection IP	IP54 ou IP65
Consommation d'air (air sec conditionné)	150 L/min
Tension d'alimentation	3x400V/50Hz/N/GND - 3x220V/60Hz/GND
Consommation d'énergie	4,6 kW
Poids de la machine	1450 kg

*Selon le produit et le système de refolement.

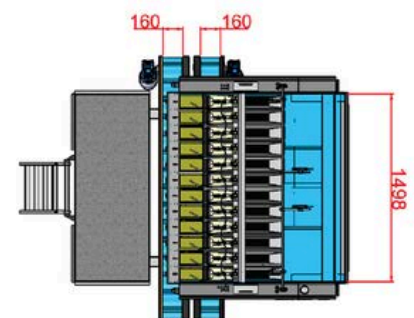
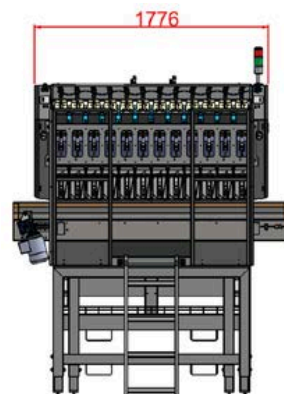
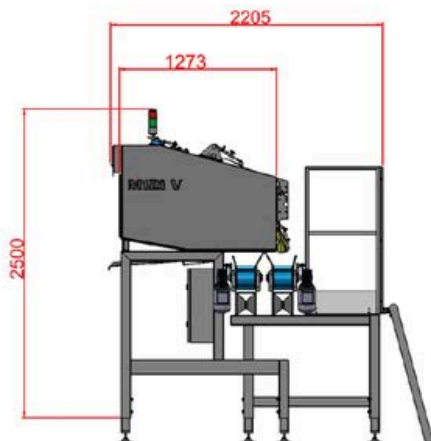

Manter International B.V.

Phileas Foggstraat 66
7825 AL Emmen
Pays-Bas

Contact

+31 591 626300
sales@manter.com
www.manter.com

