

# M10

Weighing machine



The M10 is a compact multihead weigher equipped with 10 weighing buckets, specifically designed for products such as potatoes, onions, and similar fresh produce. As one of the smaller models in our range, the M10 combines a compact footprint with a cost-effective design. It offers a weighing range from 0.5 to 25kg and achieves speeds of up to 35 drops per minute.

## Features

- Equipped with 10 weighing buckets.
- Different discharge systems possible.
- Compatible with a wide range of packaging machines.
- Intuitive touchscreen interface for easy operation.

# M10

Weighing machine

Specifications	Values
Weighing range	0.5 - 25 kg*
Capacity at 2.5kg up to	35 drops/min*
Capacity of the bucket	6 ltr
IP-rating	IP54
Air consumption (conditioned dry air)	125 L/min
Supply voltage	3×400V/50Hz/N/GND - 3×220V/60Hz/GND
Power consumption	4.1 kW
Weight of the machine	1450 kg

\*Depending on product and discharge system.

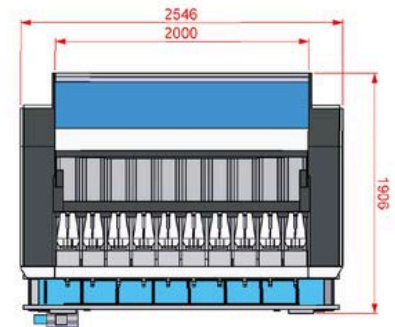
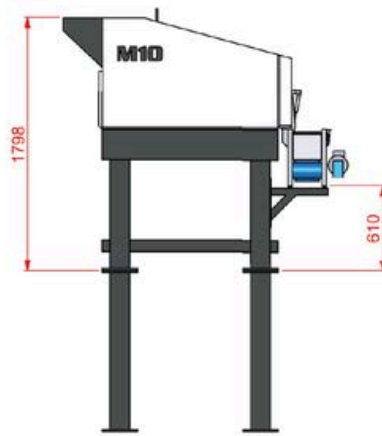
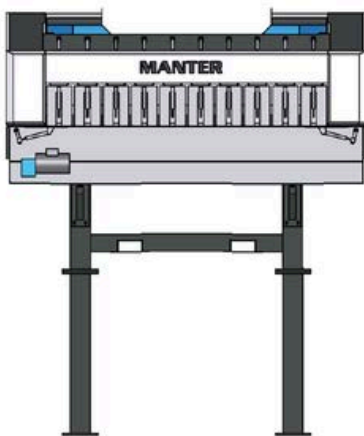

## Manter International B.V.

Phileas Foggstraat 66  
7825 AL Emmen  
The Netherlands

## Contact

+31 591 626300  
sales@manter.com  
www.manter.com





## M10

Weegmachine

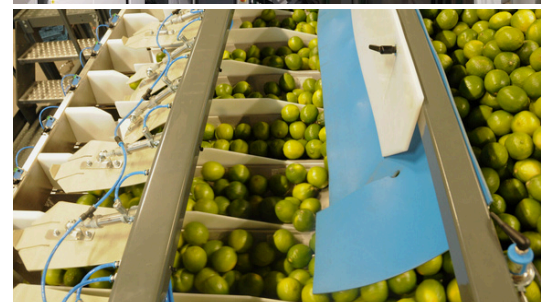

De M10 is een compacte combinatieweger, uitgerust met 10 weegbakken, speciaal ontworpen voor producten zoals aardappelen, uien en vergelijkbare verse producten. Als een van de kleinere modellen in ons assortiment combineert de M10 een compact ontwerp met een kosteneffectieve uitvoering. Hij heeft een weegbereik van 0,5 tot 25kg en behaalt snelheden tot 35 stortingen per minuut.

### Functies

- Uitgerust met 10 weegbakken.
- Verschillende lossystemen mogelijk.
- Compatibel met een breed scala aan verpakkingsmachines.
- Intuïtieve touchscreeninterface voor eenvoudige bediening.



## M10

Weegmachine

Specificaties	Waarden
Weegbereik	0.5 - 25 kg*
Capaciteit bij 2,5 kg tot	35 stortingen/min*
Inhoud van de weegbak	6 ltr
IP-classificatie	IP54
Luchtverbruik (geconditioneerde droge lucht)	125 L/min
Voedingsspanning	3x400V/50Hz/N/GND - 3x220V/60Hz/GND
Stroomverbruik	4.1 kW
Gewicht van de machine	1450 kg

\*Afhankelijk van het product en het afvoersysteem.

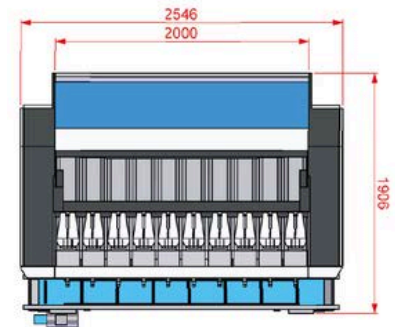
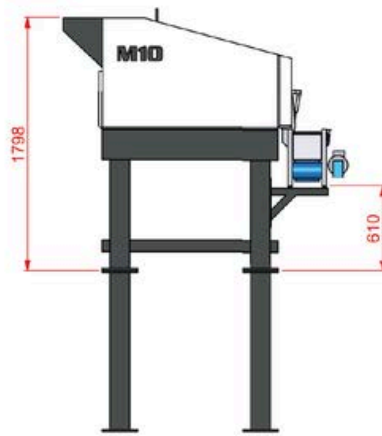
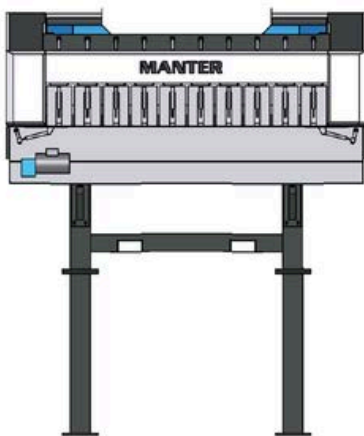

### Manter International B.V.

Phileas Foggstraat 66  
7825 AL Emmen  
Nederland

### Contact

+31 591 626300  
sales@manter.com  
www.manter.com





## M10

Pesadoras



La M10 es una pesadora multicabezal compacta equipada con 10 cangilones de pesaje, especialmente diseñada para productos como patatas, cebollas y otros productos frescos similares. Como uno de los modelos más pequeños de nuestra gama, la M10 combina un diseño compacto con una solución rentable. Ofrece un rango de pesaje de 0,5 a 25 kg y alcanza velocidades de hasta 35 descargas por minuto.

### Características

- Equipada con 10 cangilones de pesaje.
- Diversos sistemas de descarga posibles.
- Compatible con una amplia gama de máquinas de envasado.
- Interfaz de pantalla táctil intuitiva para un manejo sencillo.



## M10

Pesadoras

Presupuesto	Valores
Rango de pesaje	0.5 - 25 kg*
Capacidad de 2,5 kg hasta	35 descargas/min*
Capacidad del cabezal	6 ltr
Clasificación IP	IP54
Consumo de aire (aire seco acondicionado)	125 L/min
Tensión de alimentación	3x400V/50Hz/N/GND - 3x220V/60Hz/GND
Consumo de energía	4.1 kW
Peso de la máquina	1450 kg

\*Dependiendo del producto y sistema de descarga.

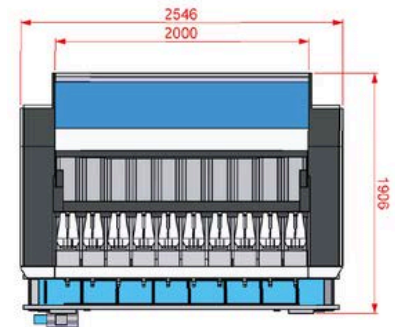
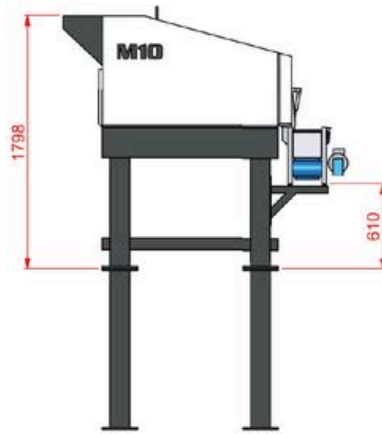
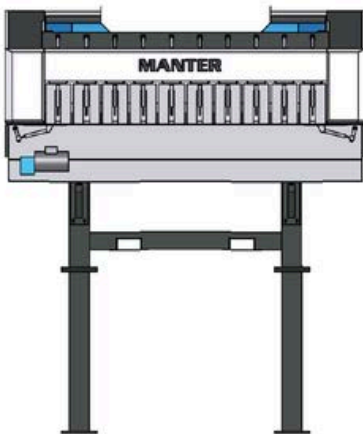

### Manter International B.V.

Phileas Foggstraat 66  
7825 AL Emmen  
Países Bajos

### Contacto

+31 591 626300  
sales@manter.com  
www.manter.com





## M10

Waage

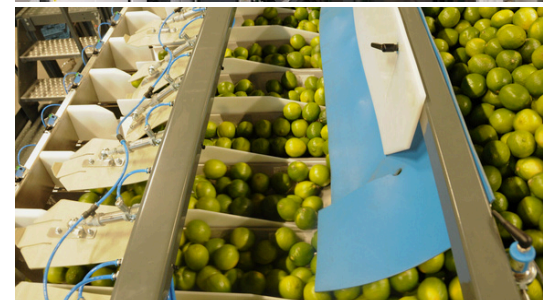

Die M10 ist eine kompakte Mehrkopfwaage, ausgestattet mit 10 Wiegebehältern, speziell für Produkte wie Kartoffeln, Zwiebeln und ähnliche Frischwaren entwickelt. Als eines der kleineren Modelle in unserem Sortiment verbindet die M10 eine kompakte Bauweise mit einem kosteneffizienten Design. Sie bietet einen Wiegebereich von 0,5 bis 25kg und erreicht Geschwindigkeiten von bis zu 35 Abwürfe pro Minute.

### Merkmale

- Ausgestattet mit 10 Wiegebehältern.
- Verschiedene Austragssysteme möglich.
- Kompatibel mit einer Vielzahl von Verpackungsmaschinen.
- Intuitive Touchscreen-Benutzeroberfläche für einfache Bedienung.



## M10

Waage

Spezifikationen	Werte
Wägebereich	0.5 - 25 kg*
Kapazität bei 2,5 kg bis zu	35 Abwürfe/min*
Fassungsvermögen des Wiegekopfs	6 ltr
IP-Schutzart	IP54
Luftverbrauch (konditionierte Trockenluft)	125 L/min
Versorgungsspannung	3x400V/50Hz/N/GND - 3x220V/60Hz/GND
Stromverbrauch	4.1 kW
Gewicht der Maschine	1450 kg

\*Abhängig vom Produkt und vom Entladesystem.

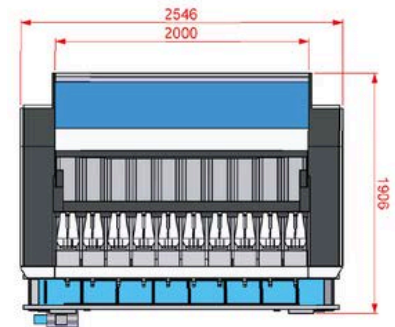
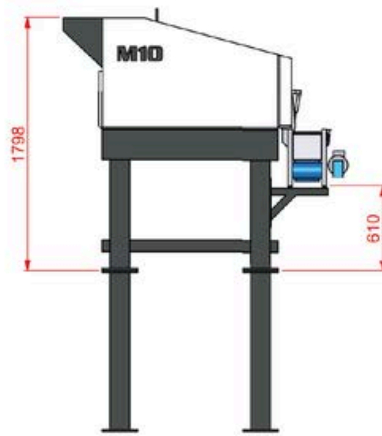
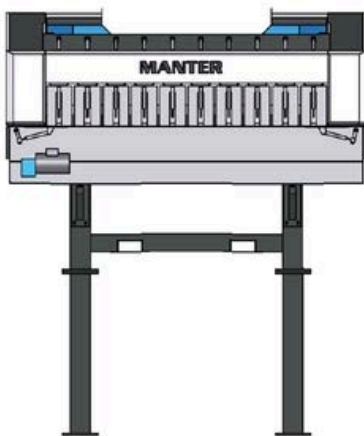

### Manter International B.V.

Phileas Foggstraat 66  
7825 AL Emmen  
Niederlande

### Kontakt

+31 591 626300  
sales@manter.com  
www.manter.com





## M10

Peseuses

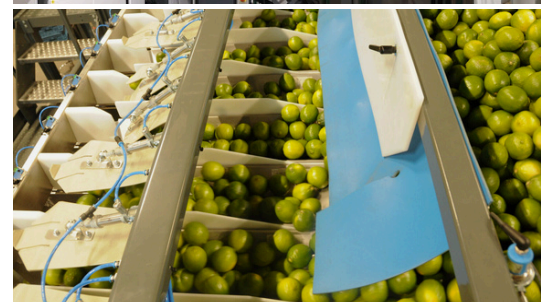

La M10 est une peseuse associative compacte équipée de 10 godets de pesage, spécialement conçue pour des produits tels que les pommes de terre, les oignons et autres produits frais similaires. En tant que l'un des modèles les plus petits de notre gamme, la M10 combine un design compact avec une solution économique. Elle offre une plage de pesage de 0,5 à 25kg et atteint des vitesses allant jusqu'à 35 déversements par minute.

### Caractéristiques

- Équipée de 10 godets de pesage.
- Différents systèmes de décharge possibles.
- Compatible avec une large gamme de machines d'emballage.
- Interface écran tactile intuitive pour une utilisation facile.

# M10

Peseuses

Caractéristiques	Valeurs
Plage de pesée	0.5 - 25 kg*
Capacité de 2,5 kg jusqu'à	35 déversements/min*
Capacité du godet	6 ltr
Indice de protection IP	IP54
Consommation d'air (air sec conditionné)	125 L/min
Tension d'alimentation	3×400V/50Hz/N/GND - 3×220V/60Hz/GND
Consommation d'énergie	4.1 kW
Poids de la machine	1450 kg

\*Selon le produit et le système de refolement.

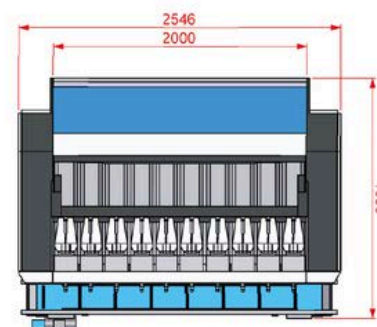
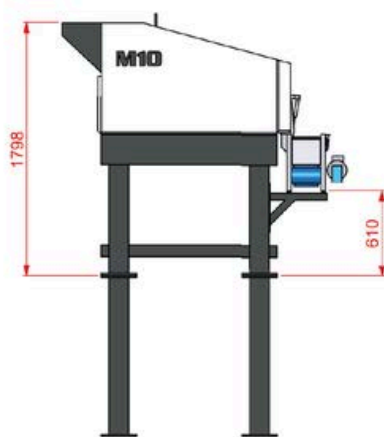
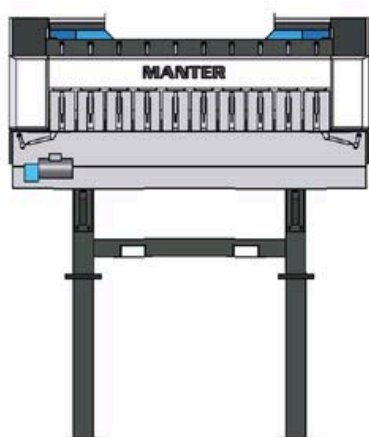

## Manter International B.V.

Phileas Foggstraat 66  
7825 AL Emmen  
Pays-Bas

## Contact

+31 591 626300  
sales@manter.com  
www.manter.com

