

# Bag Placer

Packaging machine

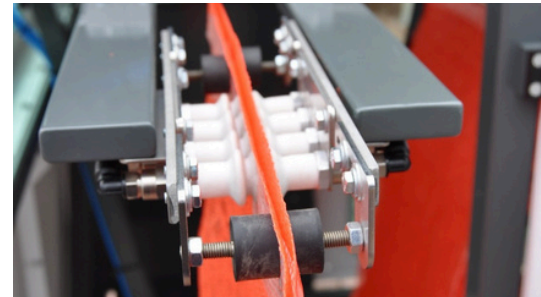

The Bag Placer is designed to efficiently place individual bags onto the filling head of the SemiPack. It can handle various different bags such as net, jute, poly and paper. An arm with suction cups picks up a bag from the wicket pins and placed underneath the filling hole, all movements are perfectly synchronized with the semi-automatic bagger to ensure seamless operation and timing. The carousel bag magazine allows for easy loading while the machine is in operation, each magazine can hold  $\pm$  250 bags. A SemiPack+ can be combined with a Bag Placer to convert them into an AutoPack, increasing capacity to up to 15 bags per minut of 25 kg.

## Features

- Automatic placement of net, jute, poly and paper bags with plastic strip
- Dual 250-bag magazines for uninterrupted operation
- Cuts labor costs significantly
- User-friendly touchscreen
- Vibrating belt gently settles product
- Combine with SemiPack+ for full AutoPack system

## Options

- Quick-change heads for paper and mesh bags

# Bag Placer

Packaging machine

| Specifications                        | Values                              |
|---------------------------------------|-------------------------------------|
| Packing range                         | 5 - 25 kg*                          |
| Bag width                             | 450 - 620 mm                        |
| Bag height                            | 560 - 800 mm                        |
| Capacity at 25kg up to                | 12 bags/min*                        |
| IP-rating                             | IP54                                |
| Air consumption (conditioned dry air) | 250 L/min                           |
| Supply voltage                        | 3x 400V/50Hz+N+GND / 3x220v60Hz+GND |
| Power consumption                     | 4,5 kW                              |
| Weight of the machine                 | 1550 kg                             |

\*Depending on product, packaging type and other possible factors.

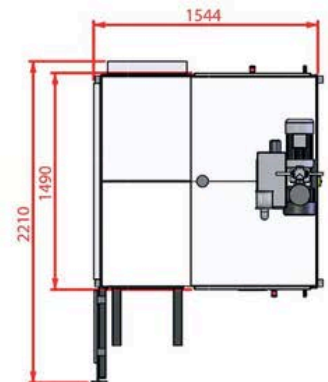
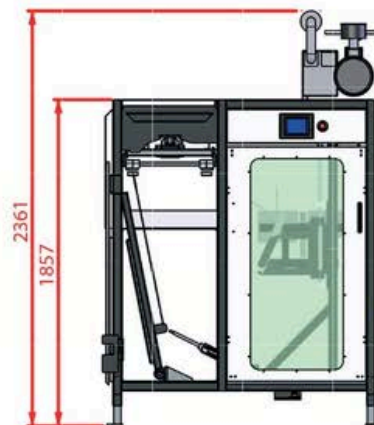
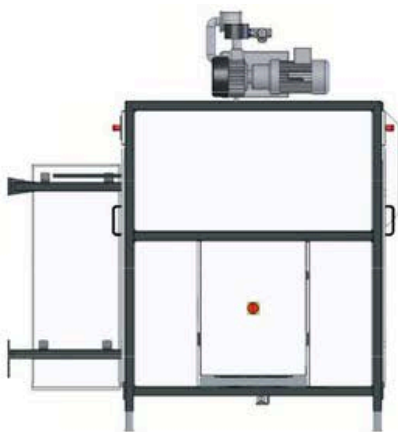

## Manter International B.V.

Phileas Foggstraat 66  
7825 AL Emmen  
The Netherlands

## Contact

+31 591 626300  
sales@manter.com  
www.manter.com



# Bag Placer

Verpakkingsmachine

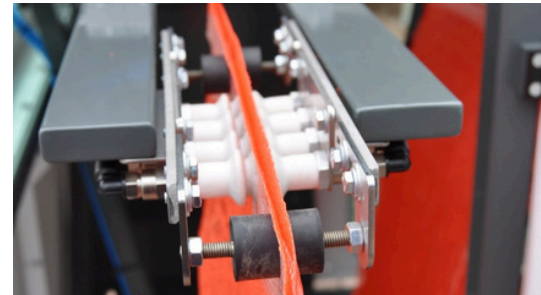

De Bag Placer is ontworpen om efficiënt individuele zakken op de vulkop van de SemiPack te plaatsen. De machine kan verschillende zaktypes verwerken, zoals net-, jute-, poly- en papieren zakken. Een arm met zuignappen pakt een zak van de wicket pins en plaatst deze onder de vulopening. Alle bewegingen zijn perfect gesynchroniseerd met de semi-automatische bagger voor een naadloze werking en optimale timing. De carousel-magazijn maakt het mogelijk om eenvoudig zakken bij te vullen terwijl de machine in bedrijf is. Elk magazijn biedt plaats aan ± 250 zakken. Een SemiPack+ kan worden gecombineerd met een Bag Placer om deze om te zetten in een AutoPack, waarmee een capaciteit tot 15 zakken per minuut van 25 kg wordt bereikt.

## Functies

- Automatische plaatsing van net-, jute-, poly- en papieren zakken met kunststof strip
- Dubbele 250-zakkenmagazijnen voor ononderbroken werking
- Aanzienlijke verlaging van arbeidskosten
- Gebruiksvriendelijk touchscreen
- Trillend transportband zorgt voor zachte productzetting
- Te combineren met SemiPack+ voor een volledig AutoPack-systeem

## Opties

- Snelwisselkoppen voor papieren en netzakken

# Bag Placer

Verpakkingsmachine

| Specificaties                                | Waarden                             |
|--|-------------------------------------|
| Verpakkingsbereik                            | 5 - 25 kg*                          |
| Zakbreedte                                   | 450 - 620 mm                        |
| Zakhoogte                                    | 560 - 800 mm                        |
| Capaciteit bij 25 kg tot                     | 12 zakken/min*                      |
| IP-classificatie                             | IP54                                |
| Luchtverbruik (geconditioneerde droge lucht) | 250 l/min                           |
| Voedingsspanning                             | 3x 400V/50Hz+N+GND / 3x220v60Hz+GND |
| Stroomverbruik                               | 4,5 kW                              |
| Gewicht van de machine                       | 1550 kg                             |

\*Afhankelijk van het product, het type verpakking en andere mogelijke factoren.

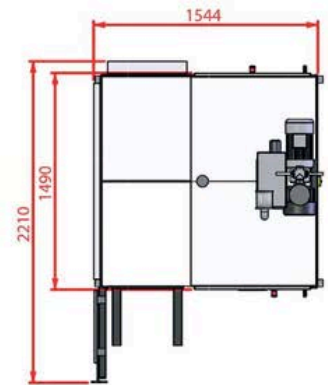
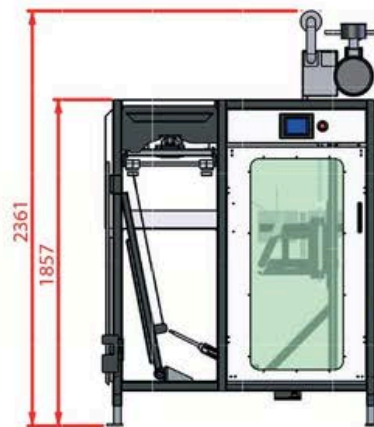
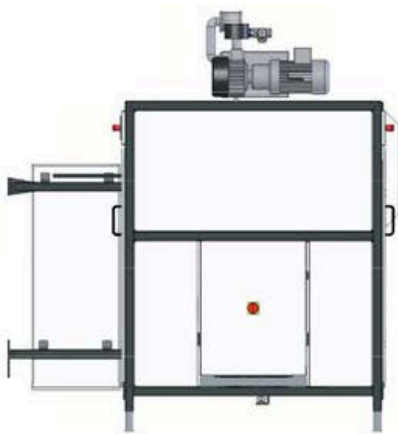

## Manter International B.V.

Phileas Foggstraat 66  
 7825 AL Emmen  
 Nederland

## Contact

+31 591 626300  
[sales@manter.com](mailto:sales@manter.com)  
[www.manter.com](http://www.manter.com)



# Bag Placer

Máquina de embalaje

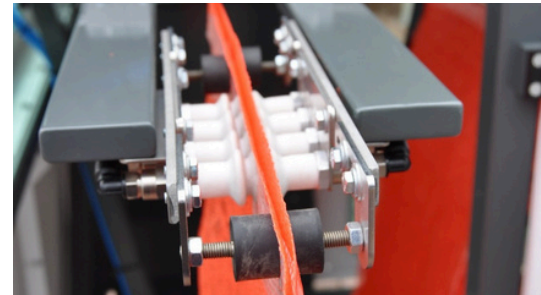

El Bag Placer está diseñado para colocar de forma eficiente sacos individuales en el cabezal de llenado de la SemiPack. Puede manejar diferentes tipos de sacos como redes, yute, polietileno y papel. Un brazo con ventosas recoge una saco de los pines tipo wicket y la coloca debajo del orificio de llenado, con todos los movimientos perfectamente sincronizados con la envasadora semiautomática para garantizar un funcionamiento continuo y preciso. El carrusel de almacenamiento permite recargar fácilmente las sacos mientras la máquina está en funcionamiento. Cada módulo puede contener aproximadamente 250 sacos. Una SemiPack+ puede combinarse con un Bag Placer para convertirse en un sistema AutoPack, aumentando la capacidad hasta 15 sacos por minuto de 25 kg.

## Características

- Colocación automática de sacos de red, yute, polietileno y papel con tira plástica
- Doble almacén de 250 sacos para operación continua
- Reducción significativa de costes laborales
- Pantalla táctil intuitiva
- Cinta vibratoria que asienta suavemente el producto
- Combinable con SemiPack+ para un sistema AutoPack completo

## Opciones

- Cabezales de cambio rápido para sacos de papel y malla

# Bag Placer

Máquina de embalaje

| Presupuesto                               | Valores                             |
|---|-------------------------------------|
| Rango de embalaje                         | 5 - 25 kg*                          |
| Ancho del saco                            | 450 - 620 mm                        |
| Altura del saco                           | 560 - 800 mm                        |
| Capacidad a 25kg hasta                    | 12 sacos/min*                       |
| Clasificación IP                          | IP54                                |
| Consumo de aire (aire seco acondicionado) | 250 L/min                           |
| Tensión de alimentación                   | 3x 400V/50Hz+N+GND / 3x220v60Hz+GND |
| Consumo de energía                        | 4,5 kW                              |
| Peso de la máquina                        | 1550 kg                             |

\*Dependiendo del producto, tipo de embalaje y otros posibles factores.

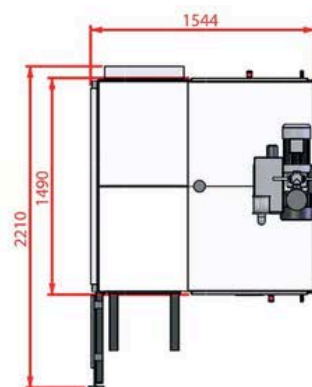
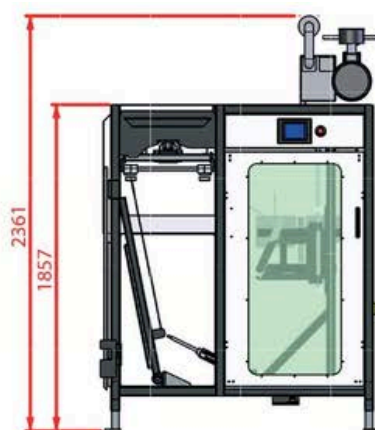
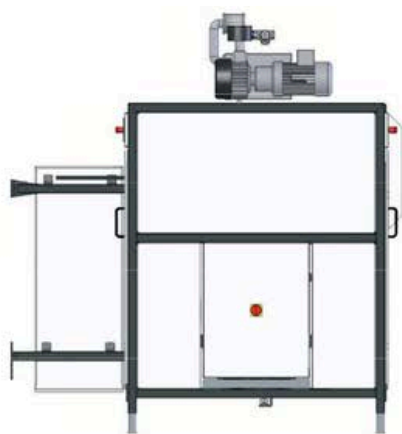

## Manter International B.V.

Phileas Foggstraat 66  
7825 AL Emmen  
Países Bajos

## Contacto

+31 591 626300  
sales@manter.com  
www.manter.com



# Bag Placer

Verpackungsmaschine

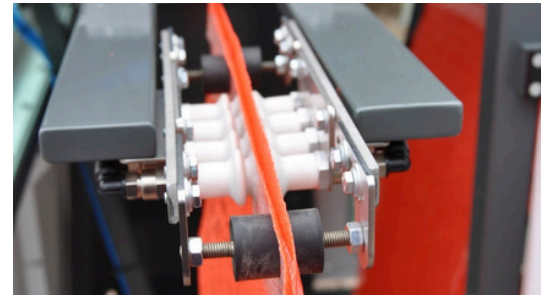

Der Bag Placer ist dafür ausgelegt, einzelne Säcke effizient auf den Füllkopf der SemiPack zu platzieren. Er kann verschiedene Sacktypen verarbeiten, wie Netz-, Jute-, Poly- und Papiersäcke. Ein Arm mit Saugnäpfen nimmt einen Sack von den Wicket-Stiften auf und platziert ihn unter der Füllöffnung. Alle Bewegungen sind perfekt mit der halbautomatischen Verpackungsmaschine synchronisiert, um einen reibungslosen und präzisen Betrieb zu gewährleisten. Das Karussell-Sackmagazin ermöglicht das einfache Nachladen während des laufenden Betriebs. Jedes Magazin fasst ca. 250 Säcke. Eine SemiPack+ kann mit einem Bag Placer kombiniert werden, um ein AutoPack-System zu bilden, wodurch eine Kapazität von bis zu 15 Säcken pro Minute à 25 kg erreicht wird.

## Merkmale

- Automatisches Platzieren von Netz-, Jute-, Poly- und Papiersäcken mit Kunststoffstreifen
- Doppelte 250-Sack-Magazine für unterbrechungsfreien Betrieb
- Deutliche Reduzierung der Arbeitskosten
- Benutzerfreundlicher Touchscreen
- Vibrationsband zur schonenden Produktablage
- Kombinierbar mit SemiPack+ für ein vollständiges AutoPack-System

## Optionen

- Schnellwechsellköpfe für Papier- und Netzbeutel

# Bag Placer

Verpackungsmaschine

| Spezifikationen                            | Werte                               |
|--|-------------------------------------|
| Verpackungsbereich                         | 5 - 25 kg*                          |
| Sackhöhe                                   | 450 - 620 mm                        |
| Sackbreite                                 | 560 - 800 mm                        |
| Kapazität bei 25 kg bis zu                 | 12 Säcke/Min.*                      |
| IP-Schutzart                               | IP54                                |
| Luftverbrauch (konditionierte Trockenluft) | 250 l/min                           |
| Versorgungsspannung                        | 3x 400V/50Hz+N+GND / 3x220v60Hz+GND |
| Stromverbrauch                             | 4,5 kW                              |
| Gewicht der Maschine                       | 1550 kg                             |

\*Abhängig vom Produkt, der Verpackungsart und anderen möglichen Faktoren.

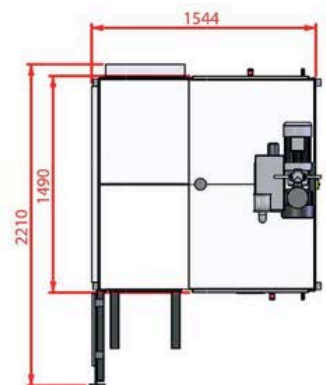
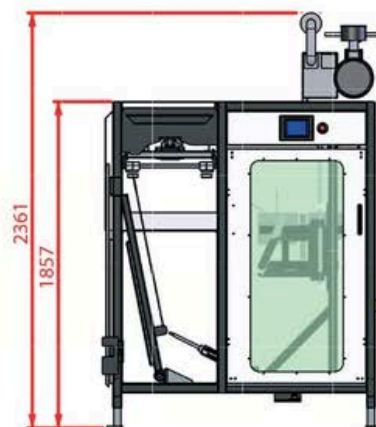
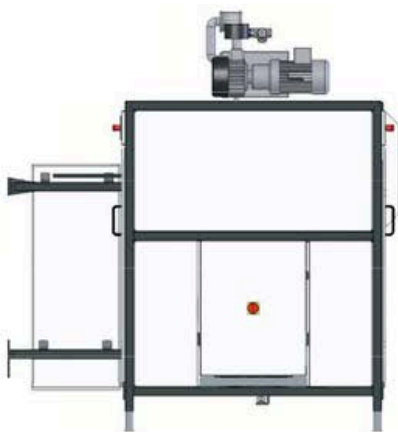

## Manter International B.V.

Phileas Foggstraat 66  
7825 AL Emmen  
Niederlande

## Kontakt

+31 591 626300  
sales@manter.com  
www.manter.com



# Bag Placer

Machine d'emballage

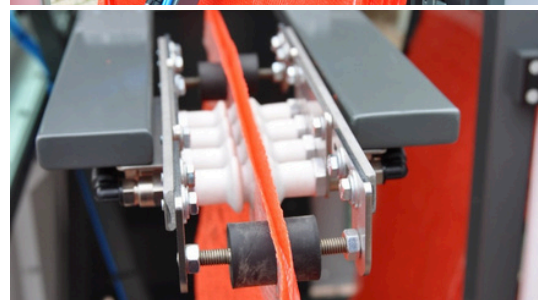

Le Bag Placer est conçu pour placer efficacement des sacs individuels sur la tête de remplissage du SemiPack. Il peut traiter différents types de sacs tels que le filet, le jute, le polyéthylène et le papier. Un bras équipé de ventouses prélève un sac sur les broches wicket et le place sous l'orifice de remplissage, tous les mouvements étant parfaitement synchronisés avec la machine de conditionnement semi-automatique afin d'assurer un fonctionnement fluide et sans interruption. Le magasin rotatif permet de recharger facilement les sacs pendant le fonctionnement de la machine. Chaque magasin peut contenir environ 250 sacs. Un SemiPack+ peut être combiné avec un Bag Placer pour devenir un système AutoPack, augmentant la capacité jusqu'à 15 sacs par minute de 25 kg.

## Caractéristiques

- Placement automatique de sacs filet, jute, polyéthylène et papier avec bande plastique
- Double magasin de 250 sacs pour un fonctionnement continu
- Réduction significative des coûts de main-d'œuvre
- Écran tactile convivial
- Convoyeur vibrant assurant un dépôt doux du produit
- Combinable avec SemiPack+ pour un système AutoPack complet

## Options

- Têtes à changement rapide pour sacs en papier et en filet

# Bag Placer

Machine d'emballage

| Caractéristiques                         | Valeurs                             |
|--|-------------------------------------|
| Gamme d'emballage                        | 5 - 25 kg*                          |
| Largeur du sac                           | 450 - 620 mm                        |
| Hauteur du sac                           | 560 - 800 mm                        |
| Capacité à 25 kg jusqu'à                 | 12 sacs/min*                        |
| Indice de protection IP                  | IP54                                |
| Consommation d'air (air sec conditionné) | 250 L/min                           |
| Tension d'alimentation                   | 3x 400V/50Hz+N+GND / 3x220v60Hz+GND |
| Consommation électrique                  | 4,5 kW                              |
| Poids de la machine                      | 1550 kg                             |

\*Selon le produit, le type d'emballage et d'autres facteurs possibles.

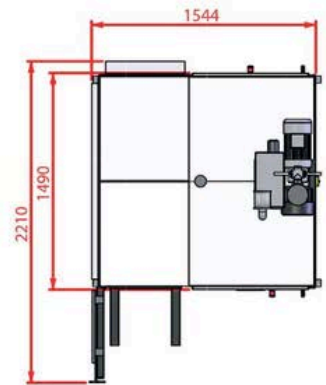
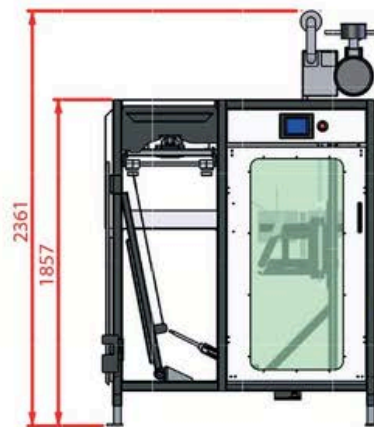
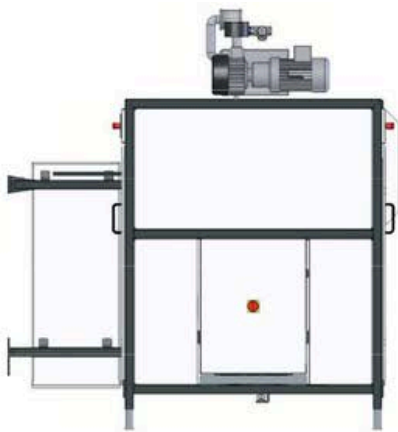

## Manter International B.V.

Phileas Foggstraat 66  
7825 AL Emmen  
Pays-Bas

## Contact

+31 591 626300  
sales@manter.com  
www.manter.com

