

MoNo Clipper

Packaging machine



The MoNo Clipper is a packaging machine for tubular netting, closed with a PE label, and specially designed for onions, shallots and citrus fruits such as lemons, limes, oranges and mandarins. The machine achieves a capacity of up to 30 bags per minute and produces mono-material net packages from 250 g to 3 kg. Thanks to the automatic tube changing system, the net supply remains continuous, ensuring uninterrupted and efficient operation. The integrated labeling unit supports various label types, including band, wineglass and seal-to-seal labels, guaranteeing flexibility in packaging and presentation.

Features

- Tubular PE net closed with a seal using a PE label
- Cost-saving: only 2 consumables (no metal or plastic clip)
- Mono-material bags, easy to recycle
- Suitable for knitted and extruded nets
- Optional printing for product identification
- Automatic tube changing for continuous production during refilling

MoNo Clipper

Packaging machine

Specifications	Values
Packing range	0.25 - 3 kg*
Net tube diameter	160 - 200 mm (default)
Capacity at 1kg up to	30 bags/min*
Air consumption (conditioned dry air)	450 L/min
IP-rating	IP54
Supply voltage	3x 400V/50Hz+N+GND / 3x220v60Hz+GND
Power consumption	4 kW
Weight of the machine	650 kg

*Depending on product, packaging type and other possible factors.

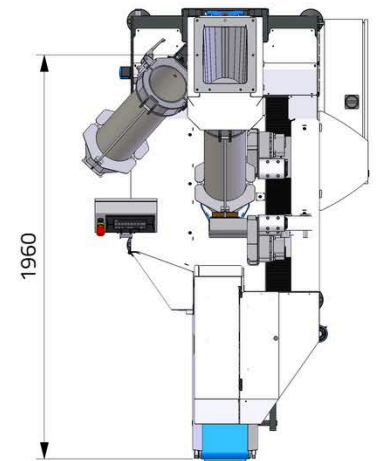
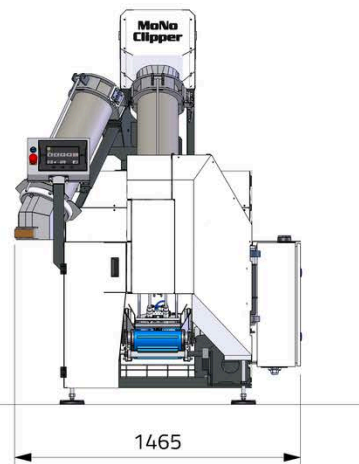
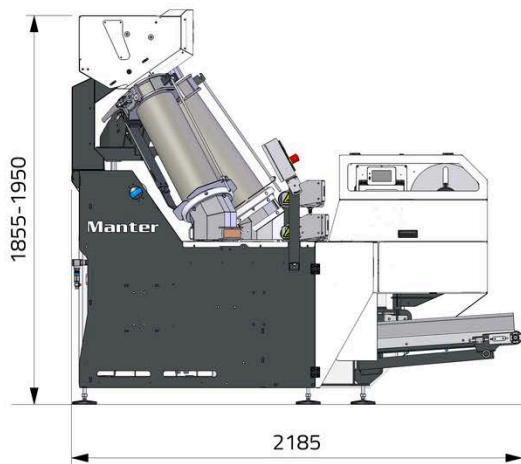

Manter International B.V.

Phileas Foggstraat 66
7825 AL Emmen
The Netherlands

Contact

+31 591 626300
sales@manter.com
www.manter.com



MoNo Clipper

Verpakkingsmachine



De MoNo Clipper is een verpakkingsmachine voor buisvormig net, gesloten met een PE-label, en speciaal ontworpen voor uien, sjalotten en citrusvruchten zoals citroenen, limoenen, sinaasappelen en mandarijnen. De machine behaalt een capaciteit tot 30 zakken per minuut en produceert monomateriaal netverpakkingen van 250 g tot 3 kg. Dankzij het automatische buiswisselsysteem blijft de nettoevoer continu, wat zorgt voor een ononderbroken en efficiënte werking. De geïntegreerde etiketteermodule ondersteunt verschillende labeltypes, waaronder strook-, wijnglas- en seal-to-seal-etiketten, waardoor flexibiliteit in verpakking en presentatie wordt gegarandeerd.

Functies

- Buisvormig PE-net gesloten met een seal via een PE-label
- Kostenbesparend: slechts 2 verbruiksartikelen (geen metalen of plastic clip)
- Monomateriaal zakken, eenvoudig te recyclen
- Geschikt voor gebreide en geëxtrudeerde netten
- Optionele bedrukking voor productidentificatie
- Automatische buiswisseling voor continue productie tijdens bijvullen

MoNo Clipper

Verpakkingsmachine

Specificaties	Waarden
Verpakkingsbereik	0,25 - 3 kg*
Netto buisdiameter	160 - 200 mm (standaard)
Capaciteit bij 1 kg tot	30 zakken/min*
Luchtverbruik (geconditioneerde droge lucht)	450 l/min
IP-classificatie	IP54
Voedingsspanning	3x 400V/50Hz+N+GND / 3x220v60Hz+GND
Stroomverbruik	4 kW
Gewicht van de machine	650 kg

*Afhankelijk van het product, het type verpakking en andere mogelijke factoren.

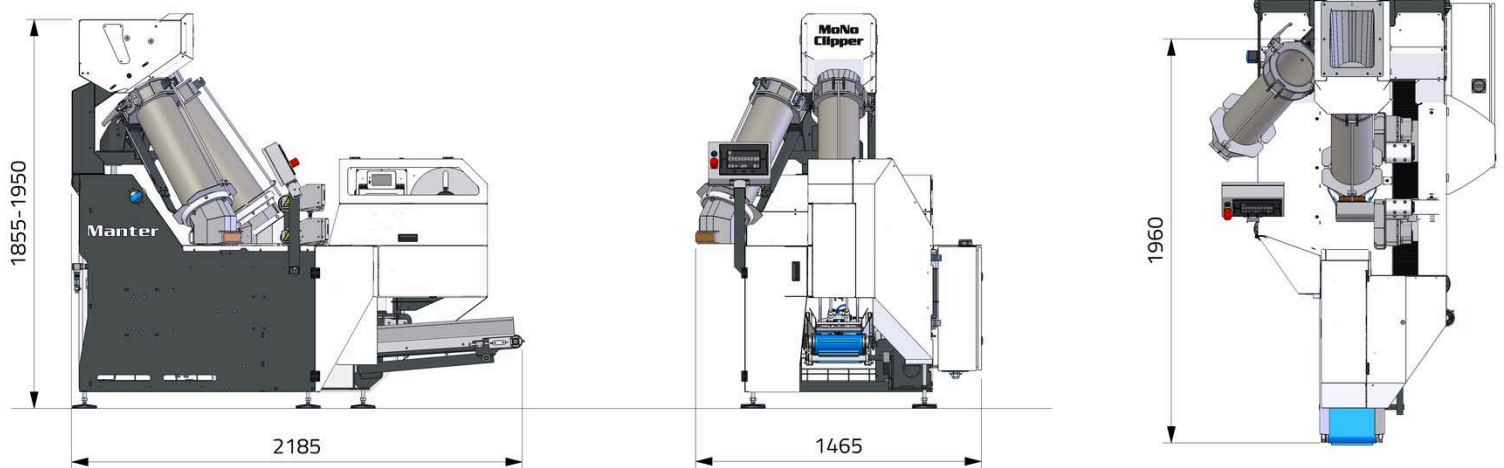

Manter International B.V.

Phileas Foggstraat 66
7825 AL Emmen
Nederland

Contact

+31 591 626300
sales@manter.com
www.manter.com



MoNo Clipper

Máquina de embalaje



La MoNo Clipper es una máquina de envasado para malla tubular, cerrada con una etiqueta de PE, especialmente diseñada para cebollas, chalotas y cítricos como limones, limas, naranjas y mandarinas. La máquina alcanza una capacidad de hasta 30 bolsas por minuto y produce envases de malla monomaterial de 250 g a 3 kg. Gracias al sistema automático de cambio de tubo, el suministro de malla se mantiene continuo, garantizando un funcionamiento ininterrumpido y eficiente. El sistema de etiquetado integrado admite varios tipos de etiquetas, incluyendo faja, tipo copa y seal-to-seal, lo que garantiza flexibilidad en el envasado y la presentación.

Características

- Malla tubular de PE cerrada con un sellado mediante etiqueta de PE
- Ahorro de costes: solo 2 consumibles (sin clip metálico o plástico)
- Bolsas monomaterial, fáciles de reciclar
- Adecuada para mallas tejidas y extruidas
- Impresión opcional para identificación del producto
- Cambio automático de tubo para producción continua durante la recarga

MoNo Clipper

Máquina de embalaje

Presupuesto	Valores
Rango de embalaje	0,25 - 3 kg*
Diámetro neto del tubo	160 - 200 mm (predeterminado)
Capacidad a 1kg hasta	30 bolsas/min*
Consumo de aire: (aire seco acondicionado)	450 L/min
Clasificación IP	IP54
Tensión de alimentación	3x 400V/50Hz+N+GND / 3x220v60Hz+GND
Consumo de energía	4 kW
Peso de la máquina	650 kg

*Dependiendo del producto, tipo de embalaje y otros posibles factores.

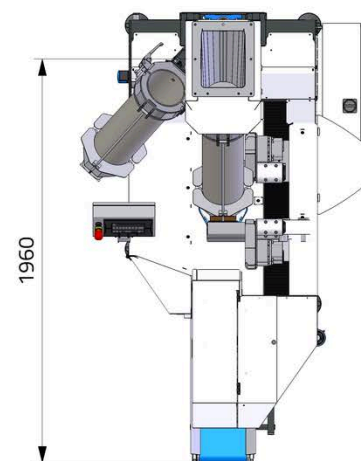
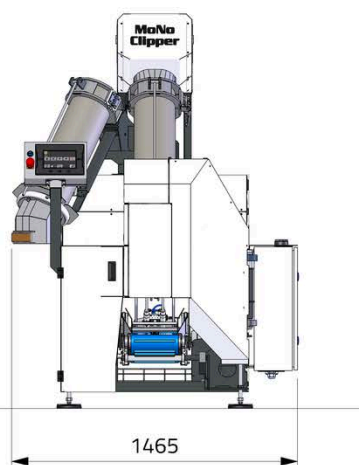
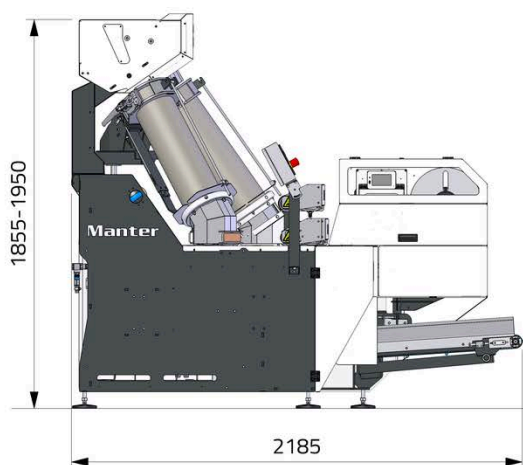

Manter International B.V.

Phileas Foggstraat 66
7825 AL Emmen
Países Bajos

Contacto

+31 591 626300
sales@manter.com
www.manter.com



MoNo Clipper

Verpackungsmaschine



Die MoNo Clipper ist eine Verpackungsmaschine für Schlauchnetze, die mit einem PE-Etikett verschlossen werden, und wurde speziell für Zwiebeln, Schalotten und Zitrusfrüchte wie Zitronen, Limetten, Orangen und Mandarinen entwickelt. Die Maschine erreicht eine Leistung von bis zu 30 Beuteln pro Minute und produziert Monomaterial-Netzverpackungen von 250 g bis 3 kg. Dank des automatischen Schlauchwechselsystems bleibt die Netzversorgung kontinuierlich, was einen unterbrechungsfreien und effizienten Betrieb gewährleistet. Das integrierte Etikettiersystem unterstützt verschiedene Etikettentypen, darunter Banderol-, Weinglas- und Seal-to-Seal-Etiketten, und bietet maximale Flexibilität bei Verpackung und Präsentation.

Merkmale

- Schlauchförmiges PE-Netz, verschlossen mit einem PE-Etikett
- Kosteneffizient: nur 2 Verbrauchsmaterialien (keine Metall- oder Kunststoffclips)
- Monomaterial-Beutel, leicht recycelbar
- Geeignet für gestrickte und extrudierte Netze
- Optionale Bedruckung zur Produktkennzeichnung
- Automatischer Schlauchwechsel für kontinuierliche Produktion während des Nachfüllens

MoNo Clipper

Verpackungsmaschine

Spezifikationen	Werte
Verpackungsbereich	0,25 - 3 kg*
Netzrohrdurchmesser	160 - 200 mm (Standard)
Kapazität bei 1 kg bis zu	30 Beutel/min*
Luftverbrauch (konditionierte Trockenluft)	450 l/min
IP-Schutzart	IP54
Versorgungsspannung	3x 400V/50Hz+N+GND / 3x220v60Hz+GND
Stromverbrauch	4 kW
Gewicht der Maschine	650 kg

*Abhängig vom Produkt, der Verpackungsart und anderen möglichen Faktoren.

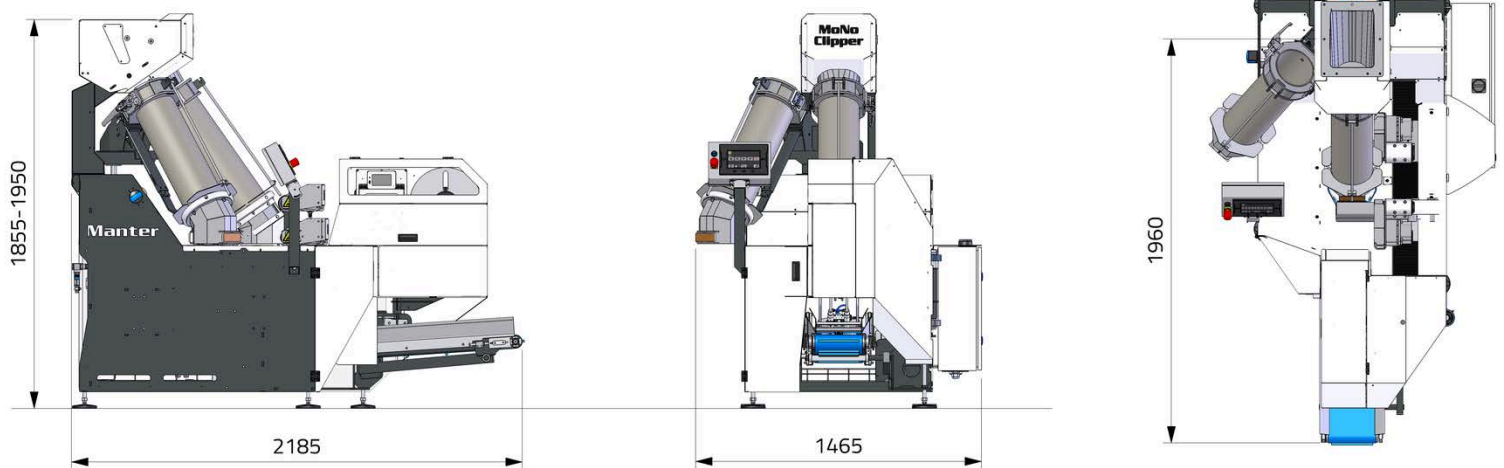

Manter International B.V.

Phileas Foggstraat 66
7825 AL Emmen
Die Niederlande

Kontakt

+31 591 626300
sales@manter.com
www.manter.com



MoNo Clipper

Machine d'emballage



La MoNo Clipper est une machine d'emballage pour filet tubulaire, fermé à l'aide d'une étiquette en PE, spécialement conçue pour les oignons, échalotes et agrumes tels que citrons, citrons verts, oranges et mandarines. La machine atteint une capacité allant jusqu'à 30 sacs par minute et produit des emballages en filet monomatériau de 250 g à 3 kg. Grâce au système automatique de changement de gaine, l'alimentation en filet reste continue, garantissant un fonctionnement ininterrompu et efficace. Le module d'étiquetage intégré prend en charge différents types d'étiquettes, notamment bande, type verre à vin et seal-to-seal, assurant une grande flexibilité d'emballage et de présentation.

Caractéristiques

- Filet tubulaire en PE fermé par scellage avec une étiquette PE
- Économique : seulement 2 consommables (pas de clip métallique ou plastique)
- Sacs monomatériau, faciles à recycler
- Compatible avec filets tricotés et extrudés
- Impression optionnelle pour identification du produit
- Changement automatique de gaine pour une production continue lors du rechargement

MoNo Clipper

Machine d'emballage

Caractéristiques	Valeurs
Gamme d'emballage	0,25 - 3 kg*
Diamètre net du tube	160 - 200 mm (par défaut)
Capacité à 1 kg jusqu'à	30 sacs/min*
Consommation d'air (air sec conditionné)	450 L/min
Indice de protection IP	IP54
Tension d'alimentation	3x 400V/50Hz+N+GND / 3x220v60Hz+GND
Consommation électrique	4 kW
Poids de la machine	650 kg

*Selon le produit, le type d'emballage et d'autres facteurs possibles.

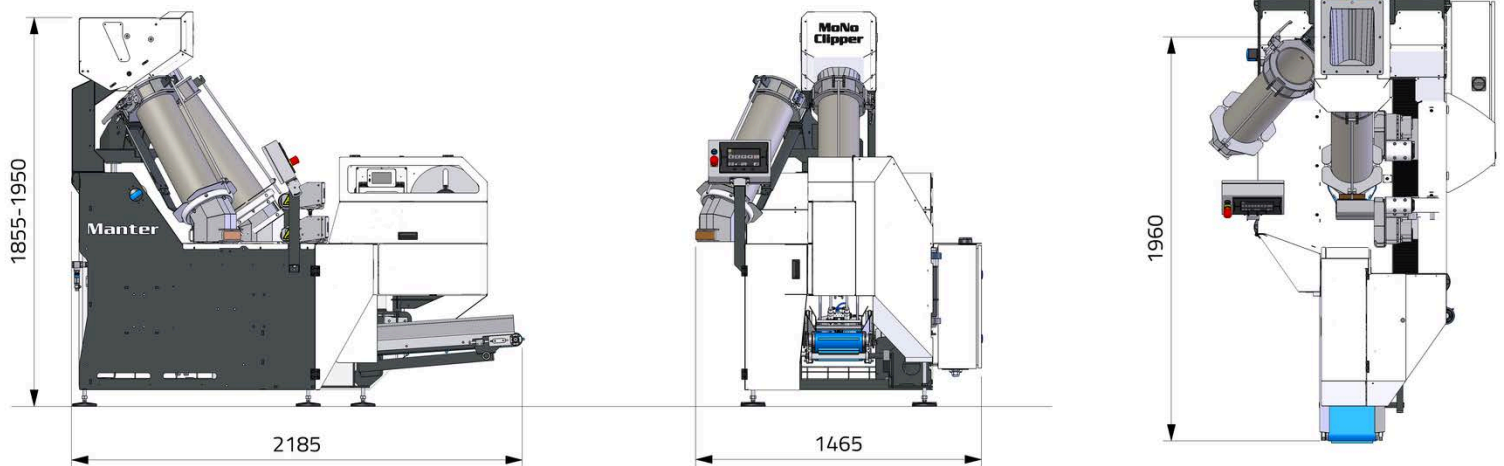

Manter International B.V.

Phileas Foggstraat 66
7825 AL Emmen
Les Pays-Bas

Contact

+31 591 626300
sales@manter.com
www.manter.com

