



Palletizer ST15

The ST15 is a semi-automatic palletizer that stacks bags quickly and firmly. The pallet import and export is not automated with this type. The machine can process up to 15 bags per minute and enables precise stacking, even with overlapping products. Optionally, the machine can be configured with a Dual Purpose manipulator for boxes and crates. You can set and operate the entire machine via the built-in touchscreen. Our palletizers can be configured entirely according to your wishes.



Specifications

- Up to 15 bags per minute*
- Bags up to 900 mm in length
- Each pallet up to 1,600 mm width
- Pallet in and outfeed: forklift or manual
- Touchscreen operation with online connection
- Safety fencing on the entry and exit sides
- Electricity: 400V / 3 Phase 0+ earth
- Compressed air 7 bar, clean and dry

* Depending on pattern, input, stack height, type of product, packaging and machine configuration

Options

- Closed stacking cage
- Adjustable stacking wall for 2 pallet sizes
- Dual Purpose manipulator to handle boxes and crates in addition to bags
- Pneumatically/electrically adjustable forming collar
- Standalone wrapping machine
- Conveyor belts in various sizes

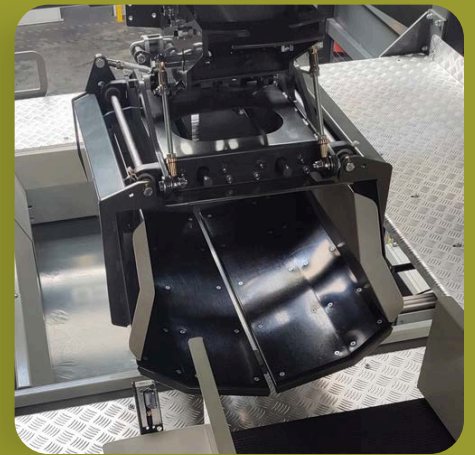
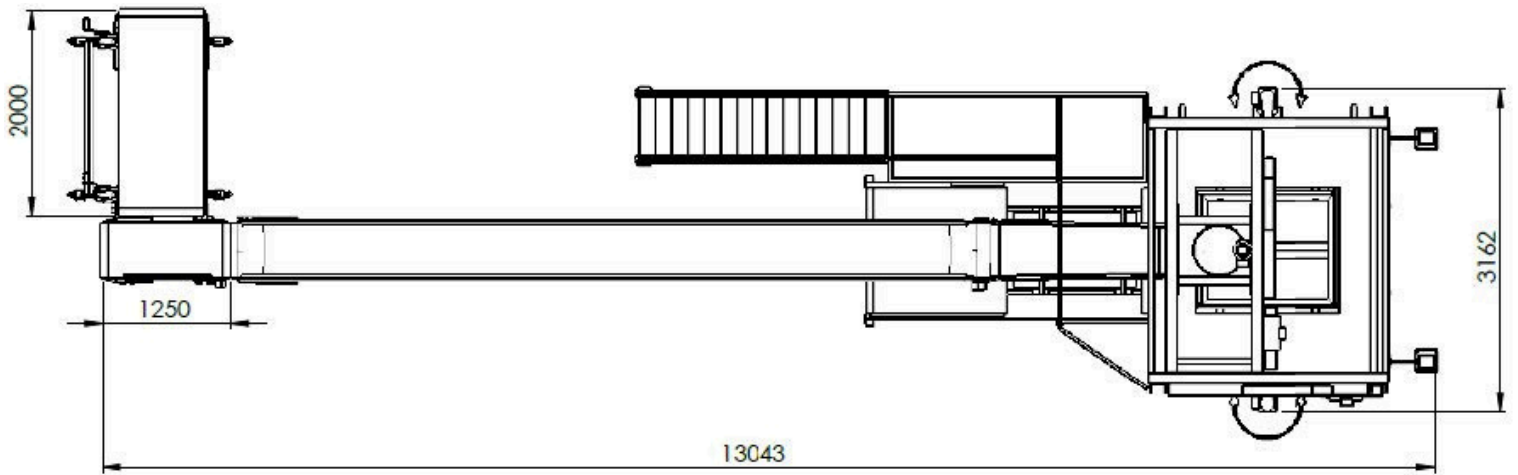
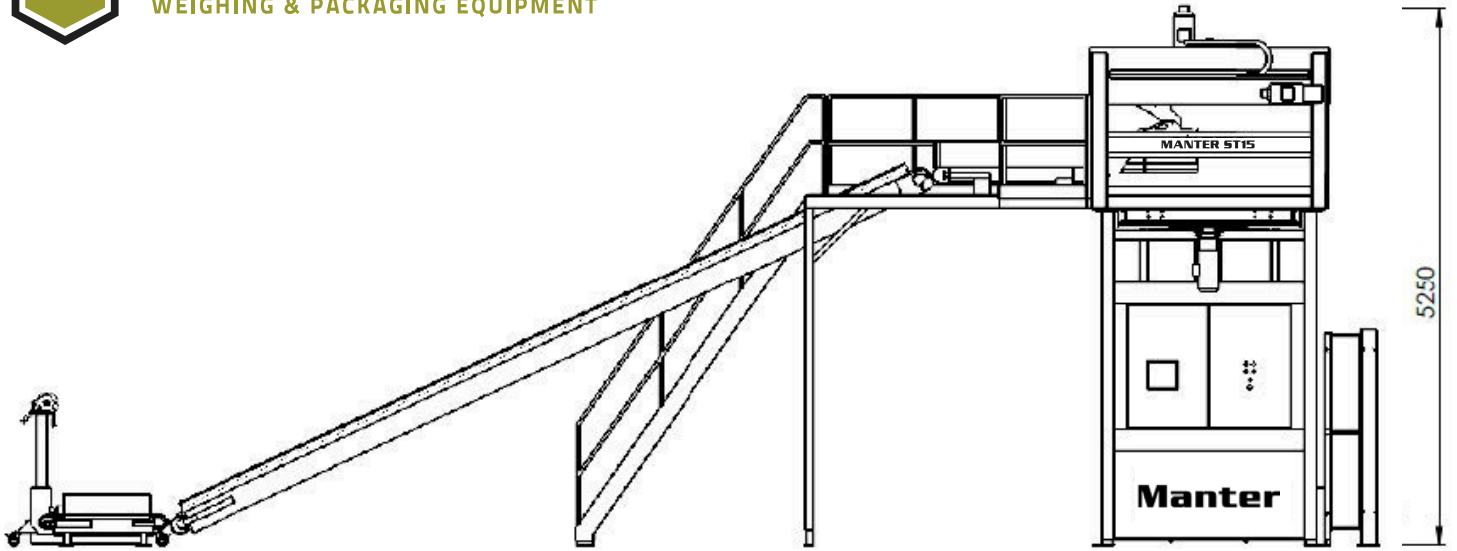



Palletiseerder ST15

De ST15 is een semi-automatische palletiseermachine die zakken snel en nauwkeurig stapelt. Het laden en lossen van pallets is bij dit model niet geautomatiseerd. De machine verwerkt tot 15 zakken per minuut en maakt nauwkeurig stapelen mogelijk, zelfs met overlappende producten. Optioneel kan de machine worden uitgerust met een multifunctionele manipulator voor kartonnen dozen. De gehele machine kan worden geconfigureerd en bediend via het geïntegreerde touchscreen. Onze palletiseermachines zijn volledig configureerbaar en kunnen worden aangepast aan uw individuele behoeften.



Functies

- Tot wel 15 zakken per minuut*
- Tassen met een lengte tot 900 mm
- Elke pallet is maximaal 1600 mm breed.
- Pallets laden en lossen: met een heftruck of handmatig.
- Bediening via touchscreen met internetverbinding
- Beveiligingsbarrières bij in- en uitgangen
- Voeding: 400 V / Driefasige stroom 0+ Aarde
- Perslucht 7 bar, schoon en droog

* Afhankelijk van het model, de invoer, de stapelhoogte, het producttype, de verpakking en de machineconfiguratie.

Opties

- Gesloten stapelkooi
- Verstelbare stapelwand voor 2 palletformaten
- Dual Purpose manipulator om naast zakken ook dozen en kratten te kunnen verwerken
- Pneumatisch/Elektrisch verstelbare formeerkraag
- Standalone wikkelmachine
- Transportbanden van diverse afmetingen



Manter[®]
WEIGHING & PACKAGING EQUIPMENT

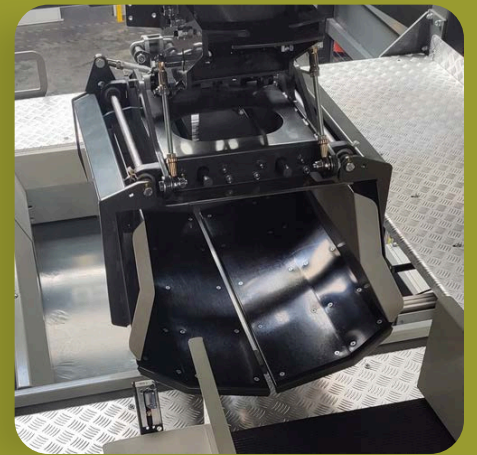
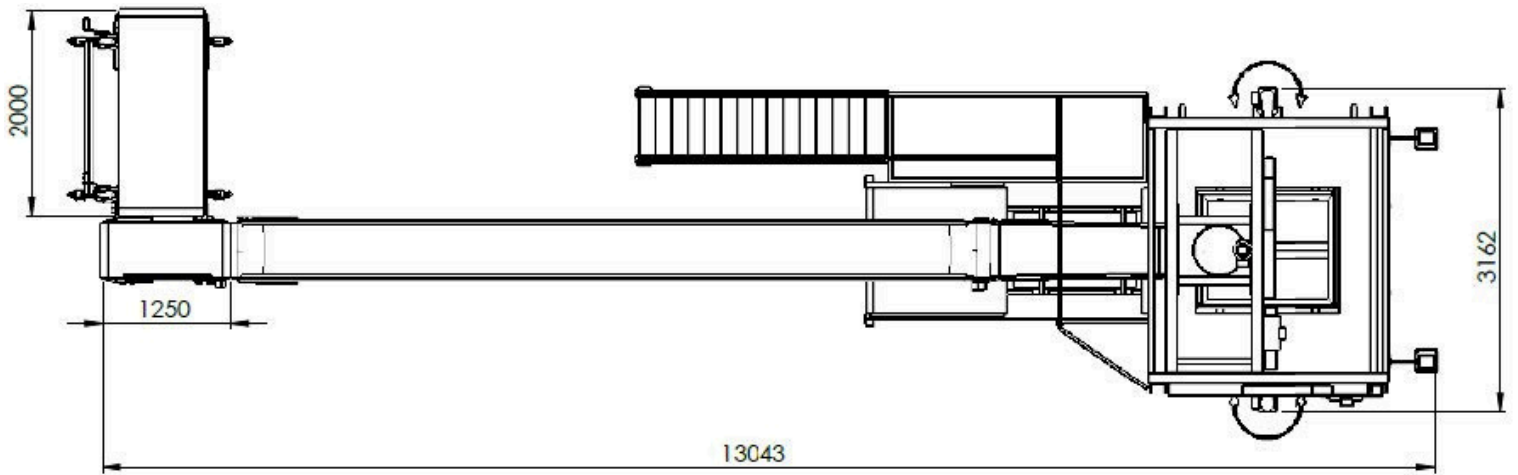
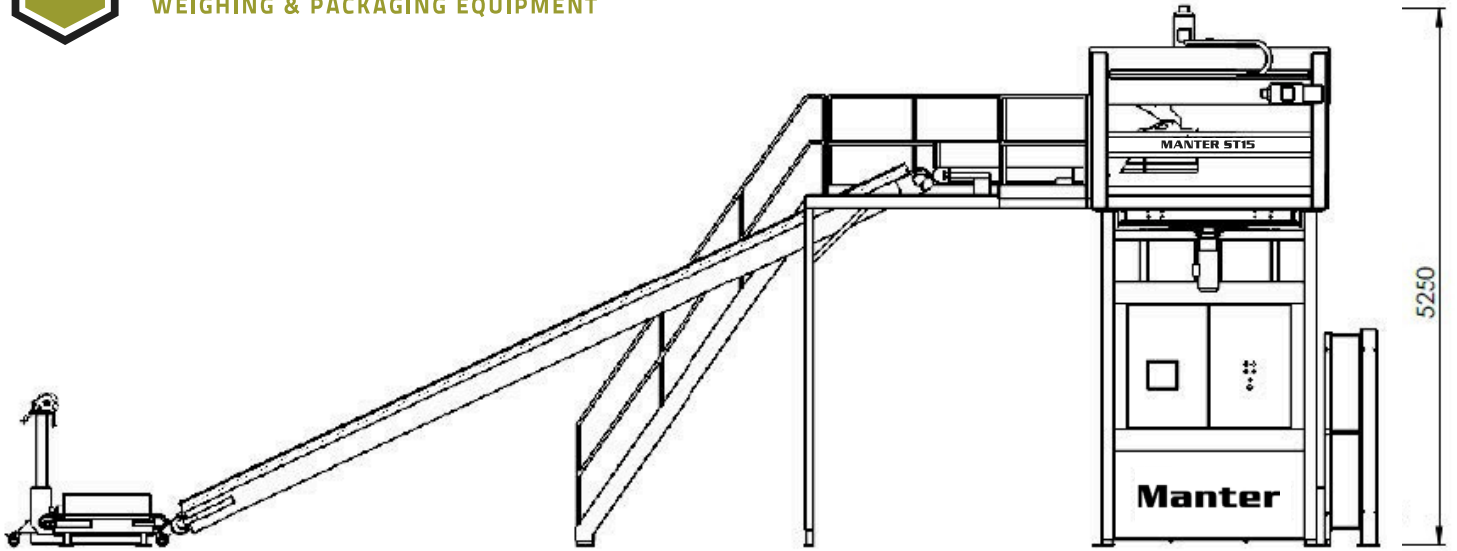



Paletizador ST15

El ST15 es un paletizador semiautomático que apila sacos con rapidez y precisión. La carga y descarga de palés no está automatizada en este modelo. La máquina procesa hasta 15 sacos por minuto y permite un apilado preciso, incluso con productos superpuestos.

Opcionalmente, puede equiparse con un manipulador multifunción para cajas de cartón. Toda la máquina se puede configurar y controlar mediante la pantalla táctil integrada. Nuestros paletizadores son totalmente configurables y se adaptan a sus necesidades individuales.



Características

- Hasta 15 sacos por minuto*
- sacos de hasta 900 mm de longitud
- Para palets de hasta 1.600 mm de ancho
- Carga y descarga de palets: carretilla elevadora o manual
- Operación de pantalla táctil con conexión en línea
- Vallas de seguridad en entradas y salidas
- Potencia: 400 V / Corriente trifásica 0+ Tierra
- Aire comprimido 7 bar, limpio y seco

* Dependiendo del modelo, entrada, altura de pila, tipo de producto, embalaje y configuración de la máquina.

Opciones

- Jaula de apilamiento cerrada
- Pared de apilamiento ajustable para 2 tamaños de palets
- Manipulador multiusos para la manipulación de cajas, cartones y sacos.
- Collarín moldeado ajustable neumática/eléctricamente
- Máquina envasadora autónoma
- Cintas transportadoras de varios tamaños



Manter[®]
WEIGHING & PACKAGING EQUIPMENT

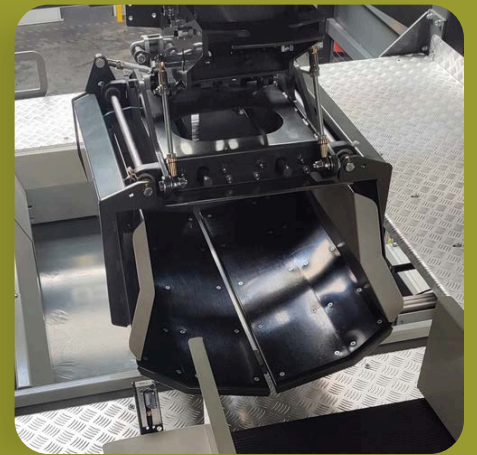
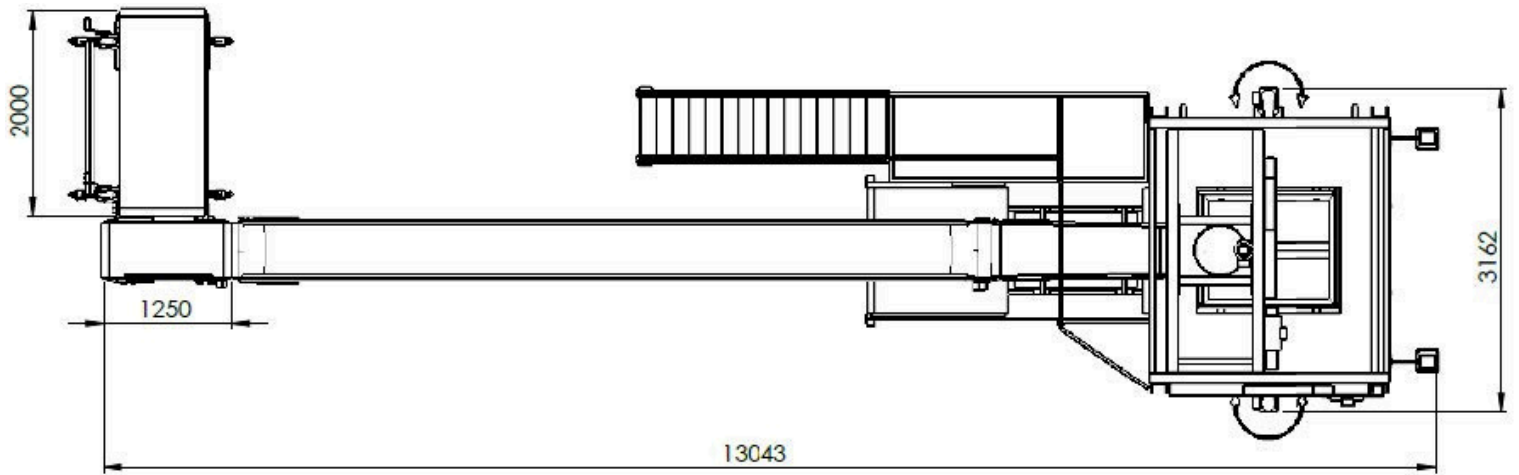
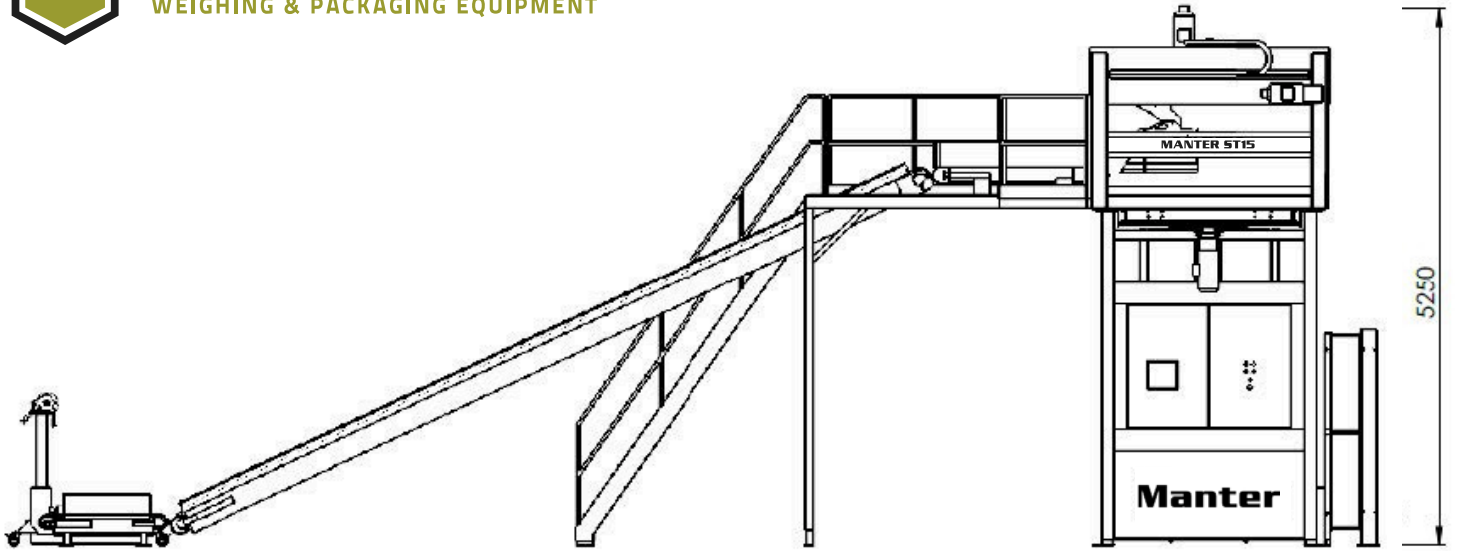



Palettierer ST15

Der ST15 ist ein halbautomatischer Palettierer, der Säcke schnell und präzise stapelt. Das Be- und Entladen der Paletten erfolgt bei diesem Modell nicht automatisiert. Die Maschine verarbeitet bis zu 15 Säcke pro Minute und ermöglicht präzises Stapeln, auch bei überlappenden Produkten. Optional kann sie mit einem Multifunktionsmanipulator für Kartons und Kisten ausgestattet werden. Über den integrierten Touchscreen lassen sich die gesamte Maschine konfigurieren und steuern. Unsere Palettierer sind vollständig konfigurierbar und erfüllen Ihre individuellen Anforderungen.



Merkmale

- Bis zu 15 Beutel pro Minute*
- Säcke bis zu 900 mm Länge
- Jede Palette bis zu 1600 mm breit
- Palettenbe- und -entladung: Gabelstapler oder manuell
- Touchscreen-Bedienung mit Online-Verbindung
- Sicherheitszäune an Ein- und Ausgängen
- Strom: 400 V / Drehstrom 0+ Erde
- Druckluft 7 bar, sauber und trocken

* Abhängig vom Modell, der Eingabe, der Stapelhöhe, dem Produkttyp, der Verpackung und der Maschinenkonfiguration

Optionen

- Geschlossener Stapelkäfig
- Verstellbare Stapelwand für 2 Palettengrößen
- Mehrzweckmanipulator zum Handhaben von Kisten und Kartons sowie von Säcken
- Pneumatisch/elektrisch verstellbarer Formkragen
- autarke Verpackungsmaschine
- Förderbänder verschiedener Größen



Manter[®]
WEIGHING & PACKAGING EQUIPMENT

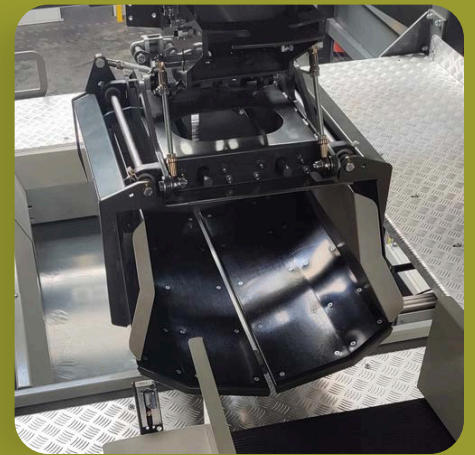
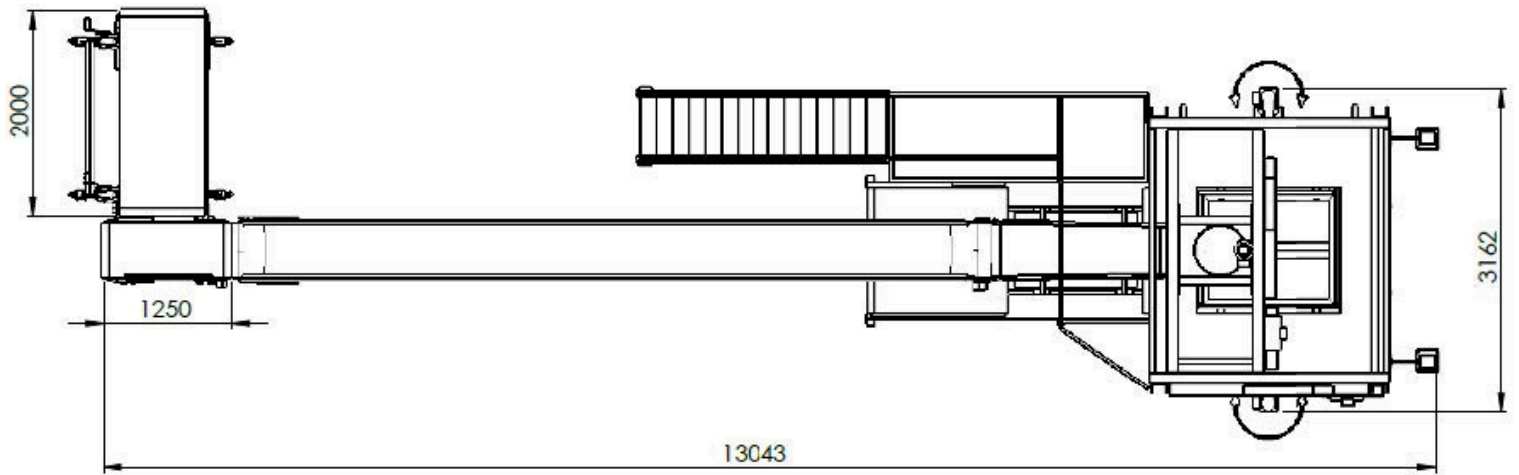
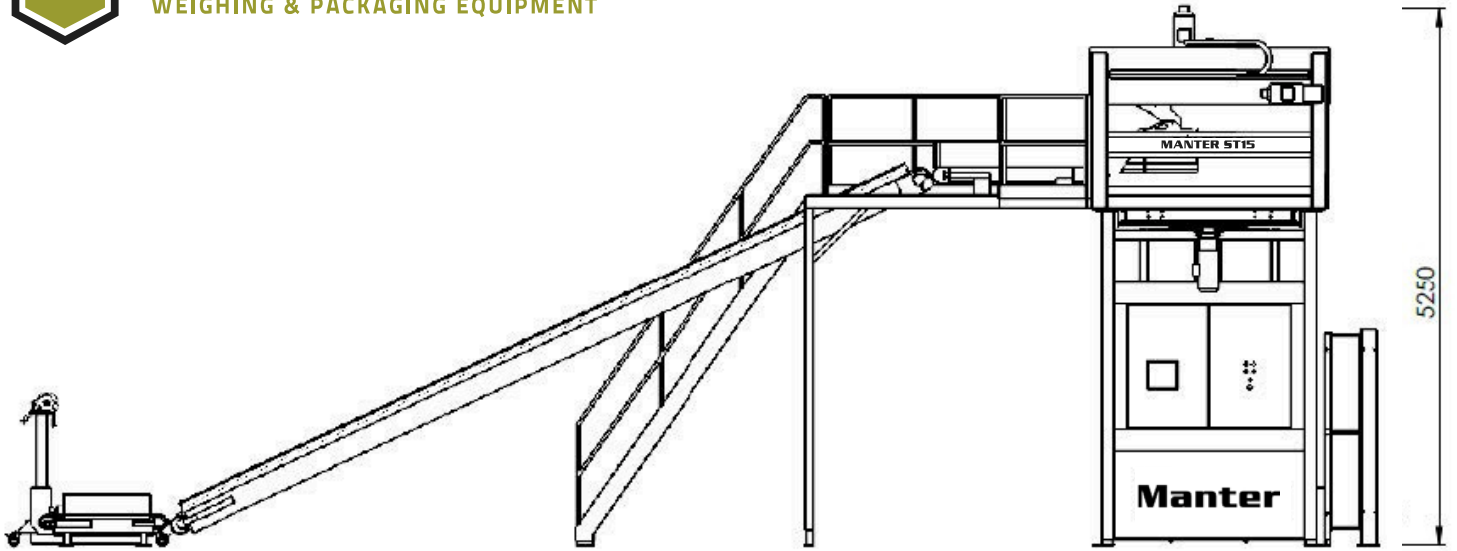



Palettiseur ST15

La ST15 est une palettiseur semi-automatique qui empile les sacs rapidement et avec précision. L'importation et l'exportation des palettes ne sont pas automatisées sur ce modèle. La machine peut traiter jusqu'à 15 sacs par minute et permet un empilage précis, même avec des produits qui se chevauchent. En option, elle peut être équipée d'un manipulateur double fonction pour les cartons et les caisses. L'écran tactile intégré permet de paramétrer et de piloter l'ensemble de la machine. Nos palettiseurs sont entièrement configurables selon vos besoins.



Caractéristiques

- Jusqu'à 15 sacs par minute*
- Sacs jusqu'à 900 mm de longueur
- Chaque palette jusqu'à 1 600 mm de largeur
- Entrée et sortie de palettes : chariot élévateur ou manuel
- Fonctionnement sur écran tactile avec connexion en ligne
- Clôture de sécurité aux entrées et sorties
- Électricité : 400 V / triphasé 0+ terre
- Air comprimé 7 bars, propre et sec

* Selon le modèle, l'entrée, la hauteur de pile, le type de produit, l'emballage et la configuration de la machine

Options

- Cage d'empilage fermée
- Paroi d'empilage réglable pour 2 tailles de palettes
- Manipulateur à double usage pour la manutention de boîtes et de caisses en plus des sacs
- Collier de formage à réglage pneumatique/électrique
- Machine d'emballage autonome
- Bandes transporteuses de différentes tailles



Manter[®]
WEIGHING & PACKAGING EQUIPMENT

