

M14 SF

Weighing machine



The M14 SF is a multihead weigher specifically designed for delicate products such as apples and pears. It features soft brushes and padded conveyor belts, allowing products to pass gently through the weigher without drop heights or bruising. The M14 SF offers a weighing range of up to 3kg and can reach speeds of up to 35 drops per minute, providing gentle yet fast weighing.

Features

- Equipped with 14 specially shaped weighing buckets, allowing the product to roll gently.
- Designed for delicate products such as apples, plums, and tomatoes.
- Various discharge systems are available.
- Can be combined with a wide range of packaging machines.
- Intuitive touchscreen interface for easy operation.

M14 SF

Weighing machine

Specifications	Values
Weighing range	0.25 - 3 kg*
Capacity at 1kg up to	35 drops/min*
Capacity of the bucket	3 ltr
IP-rating	IP54
Air consumption (conditioned dry air)	150 L/min
Supply voltage	3×400V/50Hz/N/GND - 3×220V/60Hz/GND
Power consumption	4.6 kW
Weight of the machine	1700 kg

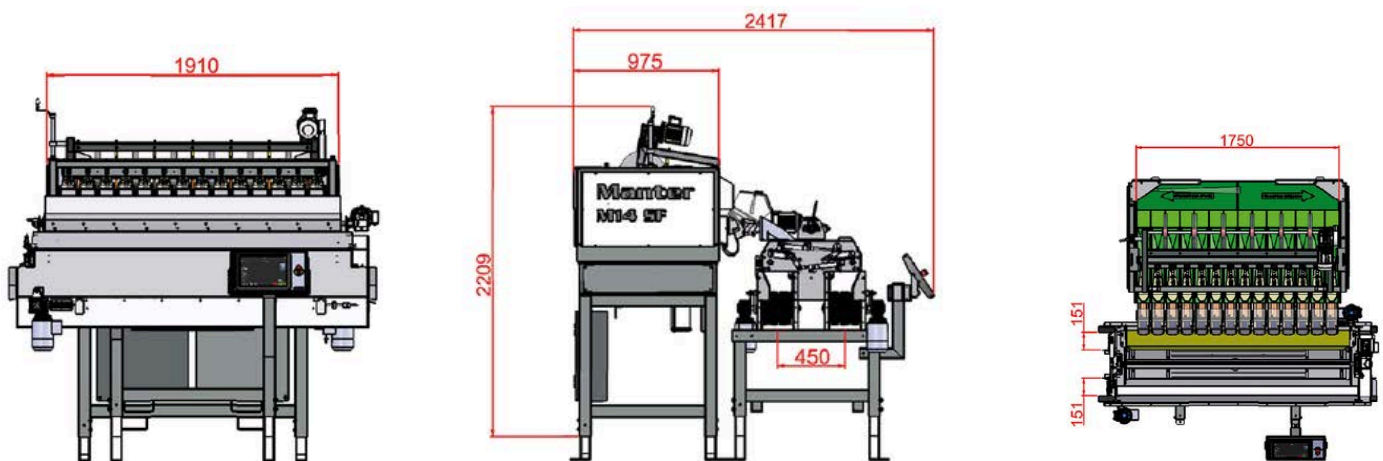

Manter International B.V.

Phileas Foggstraat 66
7825 AL Emmen
The Netherlands

Contact

+31 591 626300
sales@manter.com
www.manter.com



M14 SF

Weegmachine



De M14 SF (Soft Fill) is een combinatieveger, speciaal ontworpen voor delicate producten zoals appels en peren. Hij is uitgerust met zachte borstels en beklede transportbanden, waardoor de producten voorzichtig door de weger bewegen zonder valhoogtes of kneuzingen. De M14 SF heeft een wegbereik tot 3kg en bereikt snelheden tot 35 stortingen per minuut, waardoor zacht maar snel wegen mogelijk is.

Funcities

- Uitgerust met 14 speciaal gevormde wegbakken, waardoor het product zacht kan rollen.
- Ontworpen voor delicate producten zoals appels, pruimen en tomaten.
- Verschillende lossystemen beschikbaar.
- Combinaties met een breed scala aan verpakkingsmachines mogelijk.
- Intuïtieve touchscreeninterface voor eenvoudige bediening.

M14 SF

Weegmachine

Specificaties	Waarden
Weegbereik	0,25 - 3 kg*
Capaciteit bij 1 kg tot	35 druppels/min*
Inhoud van de weegbak	3 liter
IP-classificatie	IP54
Luchtverbruik (geconditioneerde droge lucht)	150 l/min
Voedingsspanning	3×400V/50Hz/N/GND - 3×220V/60Hz/GND
Stroomverbruik	4,6 kW
Gewicht van de machine	1700 kg

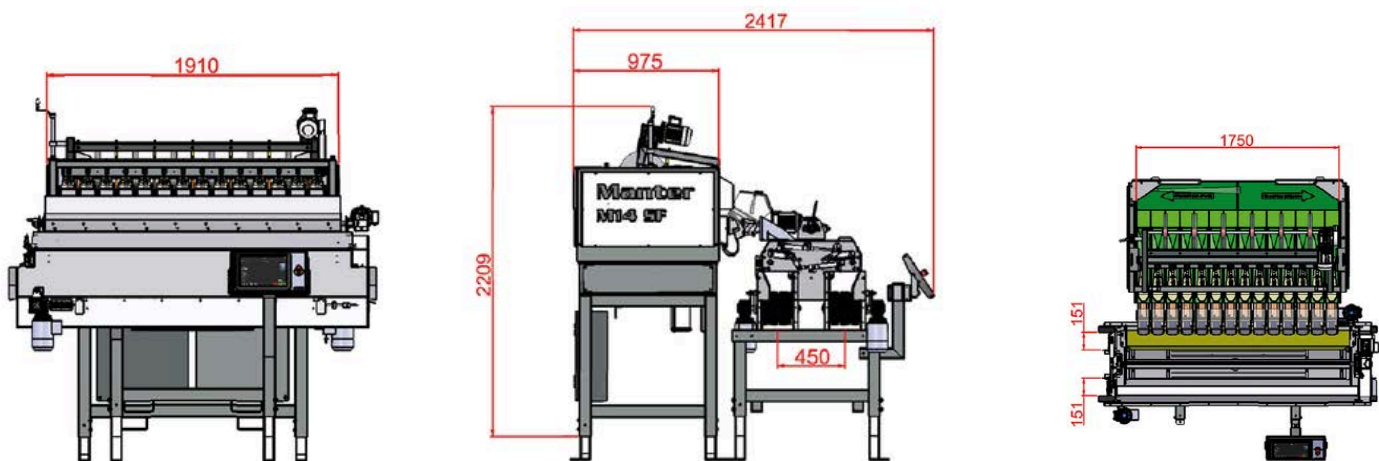

Manter International B.V.

Phileas Foggstraat 66
7825 AL Emmen
Nederland

Contact

+31 591 626300
sales@manter.com
www.manter.com



M14 SF

Pesadoras



La M14 SF (Soft Fill) es una pesadora multicabezal diseñada específicamente para productos delicados como manzanas y peras. Cuenta con cepillos suaves y cintas transportadoras acolchadas, lo que permite que los productos pasen suavemente por la pesa sin caídas ni magulladuras. La M14 SF ofrece un rango de pesaje de hasta 3kg y alcanza velocidades de hasta 35 descargas por minuto, proporcionando un pesaje delicado pero rápido.

Características

- Equipada con 14 cangilones de pesaje especialmente diseñados, que permiten que el producto ruede suavemente.
- Diseñada para productos delicados como manzanas, ciruelas y tomates.
- Diversos sistemas de descarga disponibles.
- Posibilidad de combinación con una amplia gama de máquinas de envasado.
- Interfaz de pantalla táctil intuitiva para un manejo sencillo.

M14 SF

Pesadoras

Presupuesto

Valores

Rango de pesaje	0,25 - 3 kg*
Capacidad de 1 kg hasta	35 descargas/min*
Capacidad de los cangilones	3 litros
Clasificación IP	IP54
Consumo de aire (aire seco acondicionado)	150 L/min
Tensión de alimentación	3×400V/50Hz/N/GND - 3×220V/60Hz/GND
Consumo de energía	4,6 kW
Peso de la máquina	1700 kg

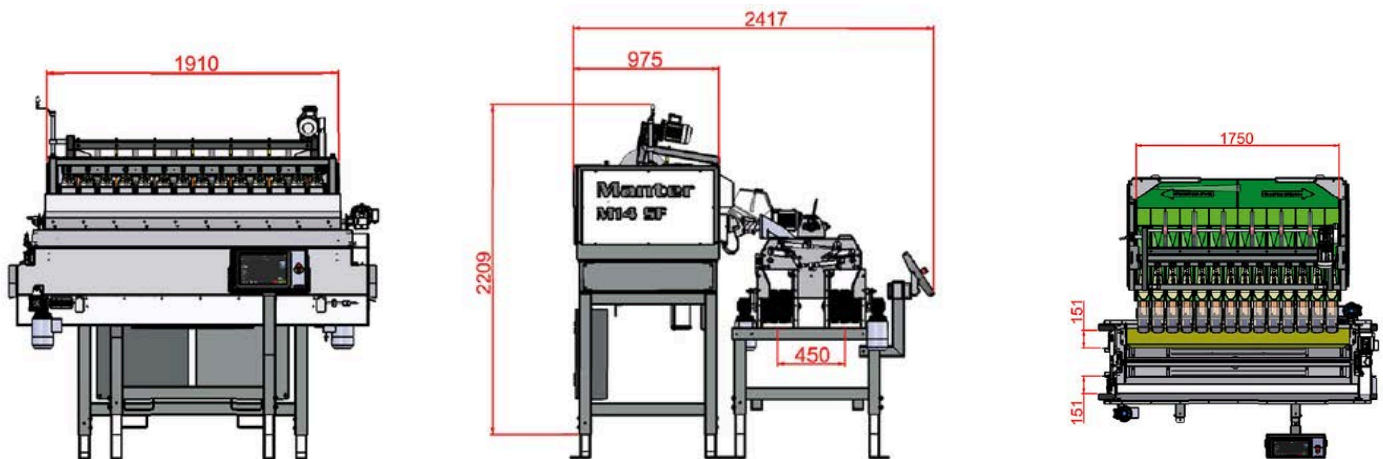

Manter International B.V.

Phileas Foggstraat 66
7825 AL Emmen
Países Bajos

Contacto

+31 591 626300
sales@manter.com
www.manter.com



M14 SF

Waage



Die M14 SF (Soft Fill) ist eine Mehrkopfwaage, speziell für empfindliche Produkte wie Äpfel und Birnen entwickelt. Sie verfügt über weiche Bürsten und gepolsterte Förderbänder, wodurch die Produkte sanft durch die Waage laufen, ohne Fallhöhen oder Quetschungen. Die M14 SF bietet einen Wiegebereich von bis zu 3kg und erreicht Geschwindigkeiten von bis zu 35 Portionen pro Minute, was ein sanftes, aber schnelles Wiegen ermöglicht.

Merkmale

- Ausgestattet mit 14 speziell geformten Wiegebehältern, die ein sanftes Rollen des Produkts ermöglichen.
- Für empfindliche Produkte wie Äpfel, Pflaumen und Tomaten konzipiert.
- Verschiedene Austragssysteme möglich.
- Kombination mit einer Vielzahl von Verpackungsmaschinen möglich.
- Intuitive Touchscreen-Benutzeroberfläche für einfache Bedienung.

M14 SF

Waage

Spezifikationen	Werte
Wägebereich	0,25 - 3 kg*
Kapazität bei 1 kg bis zu	35 Abwürfe/Min*
Fassungsvermögen des Wiegekopfs	3 Liter
IP-Schutzart	IP54
Luftverbrauch (konditionierte Trockenluft)	150 l/min
Versorgungsspannung	3×400V/50Hz/N/GND - 3×220V/60Hz/GND
Stromverbrauch	4,6 kW
Gewicht der Maschine	1700 kg

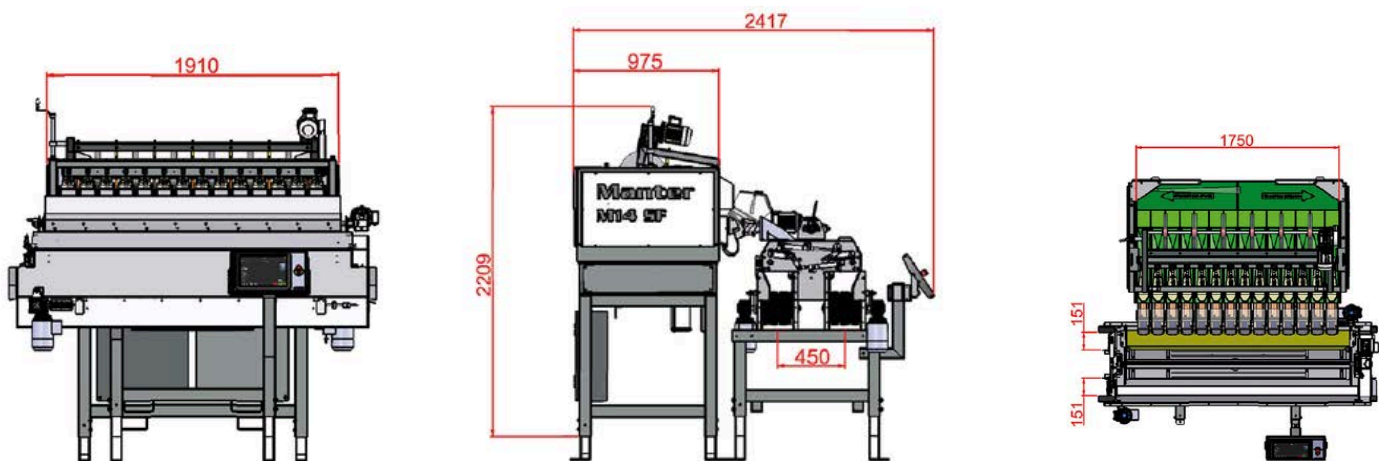

Manter International B.V.

Phileas Foggstraat 66
7825 AL Emmen
Niederlande

Kontakt

+31 591 626300
sales@manter.com
www.manter.com



M14 SF

Peseuses



La M14 SF (Soft Fill) est une peseuse associative spécialement conçue pour les produits délicats tels que les pommes et les poires. Elle est équipée de brosses douces et de convoyeurs rembourrés, permettant aux produits de passer doucement dans la peseuse sans chute ni ecchymoses. La M14 SF offre une plage de pesée allant jusqu'à 3kg et peut atteindre des vitesses de 35 déversements par minute, assurant un pesage doux mais rapide.

Caractéristiques

- Équipée de 14 godets de pesage spécialement conçus, permettant au produit de rouler doucement.
- Conçue pour des produits délicats tels que pommes, prunes et tomates.
- Différents systèmes de décharge possibles.
- Combinaison possible avec une large gamme de machines d'emballage.
- Interface écran tactile intuitive pour une utilisation facile.

M14 SF

Peseuses

Caractéristiques	Valeurs
Plage de pesée	0,25 - 3 kg*
Capacité à 1 kg jusqu'à	35 déversements/min*
Capacité du godet	3 litres
Indice de protection IP	IP54
Consommation d'air (air sec conditionné)	150 L/min
Tension d'alimentation	3×400V/50Hz/N/GND - 3×220V/60Hz/GND
Consommation d'énergie	4,6 kW
Poids de la machine	1700 kg

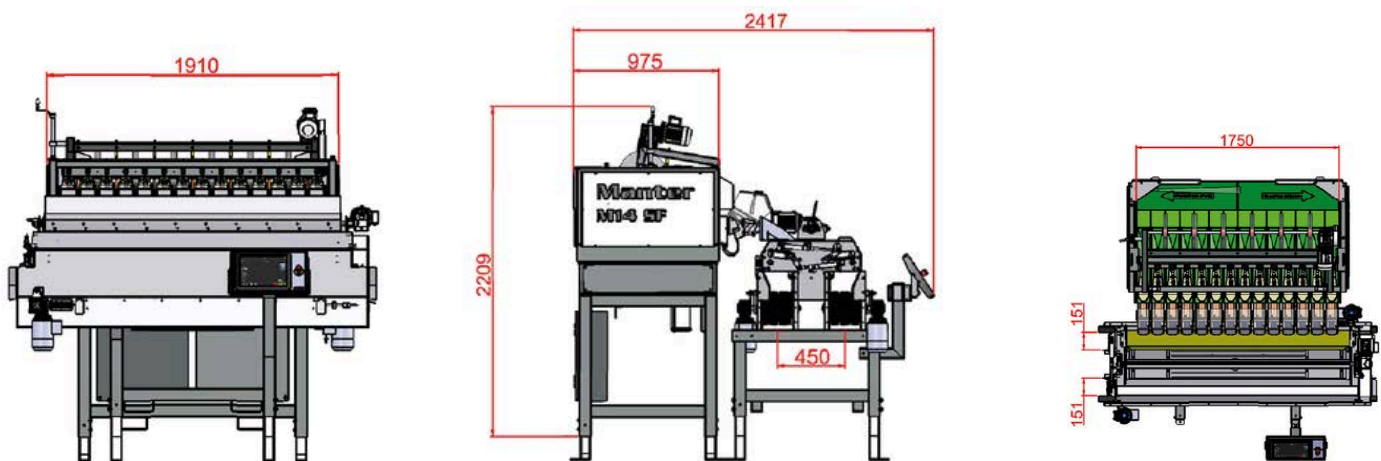

Manter International B.V.

Phileas Foggstraat 66
7825 AL Emmen
Pays-Bas

Contact

+31 591 626300
sales@manter.com
www.manter.com

