

M12i Fr

Weighing machine



The M12i Fr (Frozen) is a stainless steel multihead weigher specifically designed for the frozen food industry. It is ideal for processors handling individually quick-frozen (IQF) products, as well as fish, meat, and poultry. The M12i Fr has a weighing range of 250g to 10kg and can achieve speeds of up to 50 drops per minute.

Features

- Equipped with 12 weighing buckets inline.
- Suitable for accurate weighing of fresh products and deep-frozen IQF foods, including frozen fish, meat, and vegetables.
- Non-stick patterned sheet metal for improved product flow.
- Multiple discharge configurations available.
- Compatible with a wide range of packaging machines.
- Intuitive touchscreen interface for easy operation.

M12i Fr

Weighing machine

| Specifications | Values |
|---------------------------------------|-------------------------------------|
| Weighing range | 0.5 - 5 kg* |
| Capacity at 2.5kg up to | 50 drops/min* |
| Capacity of the bucket | 9 ltr |
| IP-rating | IP65 |
| Air consumption (conditioned dry air) | 150 L/min |
| Supply voltage | 3×400V/50Hz/N/GND - 3×220V/60Hz/GND |
| Power consumption | 5.5 kW |
| Weight of the machine | 2450 kg |

*Depending on product and discharge system.

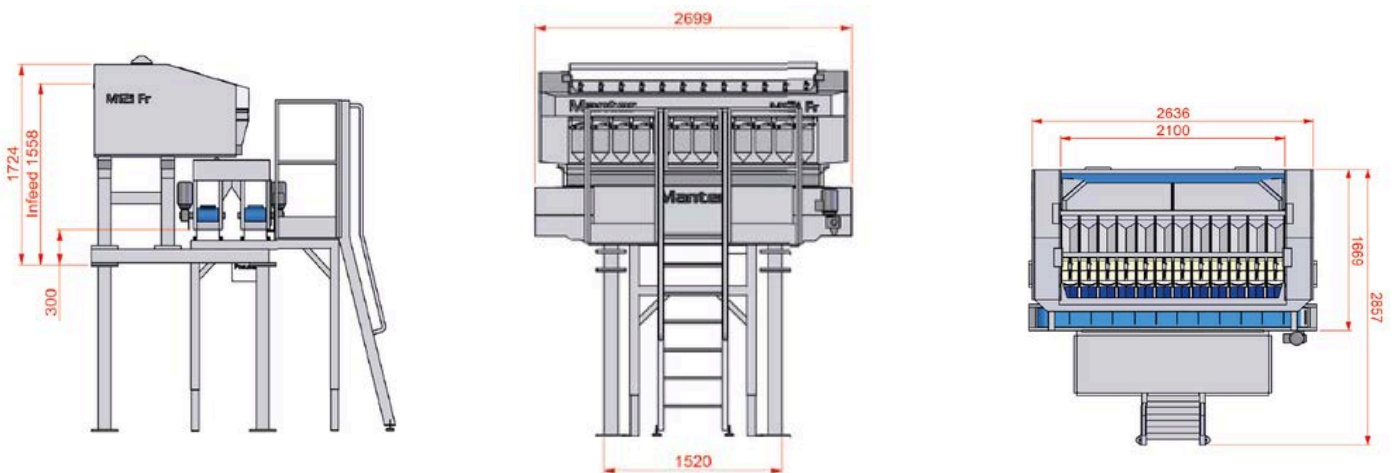

Manter International B.V.

Phileas Foggstraat 66
7825 AL Emmen
The Netherlands

Contact

+31 591 626300
sales@manter.com
www.manter.com



M12i Fr

Weegmachine



De M12i Fr (Frozen) is een combinatieweger van roestvrij staal, speciaal ontworpen voor de diepvriesindustrie. Hij is ideaal voor verwerkers die individueel snelgevroren (IQF) producten verwerken, evenals vis, vlees en gevogelte. De M12i Fr heeft een weegbereik van 250 g tot 10 kg en kan snelheden van tot 50 stortingen per minuut behalen.

Functies

- Uitgerust met 12 weegbakken in lijn.
- Geschikt voor nauwkeurig wegen van verse producten en diepgevroren IQF-voeding, waaronder vis, vlees en groenten.
- Anti-aanbak patroon op het metaal voor verbeterde productdoorstroming.
- Meerdere lossingsconfiguraties beschikbaar.
- Compatibel met een breed scala aan verpakkingsmachines.
- Intuïtieve touchscreeninterface voor eenvoudige bediening.

M12i Fr

Weegmachine

| Specificaties | Waarden |
|--|-------------------------------------|
| Weegbereik | 0,5 - 5 kg* |
| Capaciteit bij 2,5 kg tot | 50 stortingen/min* |
| Inhoud van de weegbak | 9 liter |
| IP-classificatie | IP65 |
| Luchtverbruik (geconditioneerde droge lucht) | 150 l/min |
| Voedingsspanning | 3x400V/50Hz/N/GND - 3x220V/60Hz/GND |
| Stroomverbruik | 5,5 kW |
| Gewicht van de machine | 2450 kg |

*Afhankelijk van het product en het afvoersysteem.

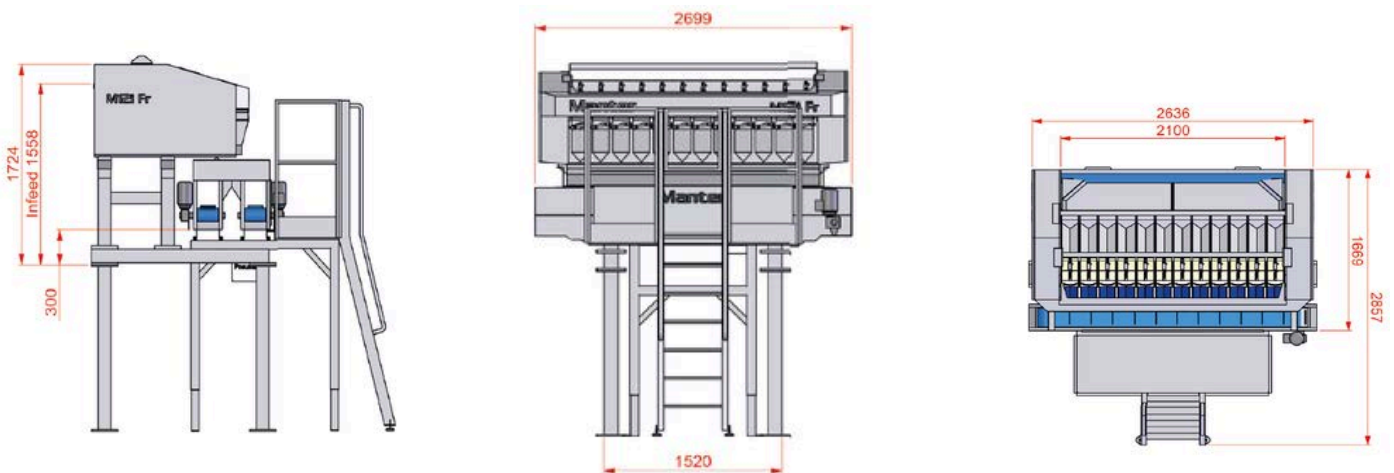

Manter International B.V.

Phileas Foggstraat 66
7825 AL Emmen
Nederland

Contact

+31 591 626300
sales@manter.com
www.manter.com



M12i Fr

Máquina de pesaje



La M12i Fr (Frozen) es una pesada multicabezal de acero inoxidable, diseñada específicamente para la industria de alimentos congelados. Ideal para procesadores que manejan productos congelados individualmente (IQF), así como pescado, carne y aves. La M12i Fr ofrece un rango de pesaje de 250g a 10kg y puede alcanzar velocidades de hasta 50 caídas por minuto.

Características

- Equipada con 12 cangilones de pesaje en línea.
- Adecuada para un pesaje preciso de productos frescos y alimentos congelados IQF, incluyendo pescado, carne y verduras.
- Chapa metálica con patrón antiadherente para mejorar el flujo del producto.
- Múltiples configuraciones de descarga disponibles.
- Compatible con una amplia gama de máquinas de envasado.
- Interfaz de pantalla táctil intuitiva para un manejo sencillo.

M12i Fr

Máquina de pesaje

Presupuesto

Valores

| | |
|---|--|
| Rango de pesaje | 0,5 - 5 kg* |
| Capacidad de 2,5 kg hasta | 50 descargas/min* |
| Capacidad de los cangilones | 9 litros |
| Clasificación IP | IP65 |
| Consumo de aire (aire seco acondicionado) | 150 L/min |
| Tensión de alimentación | 3x400V/50Hz/N/GND - 3x220V/60Hz/GND |
| Consumo de energía | 5,5 kW |
| Peso de la máquina | 2450 kg |

*Dependiendo del producto y sistema de descarga.

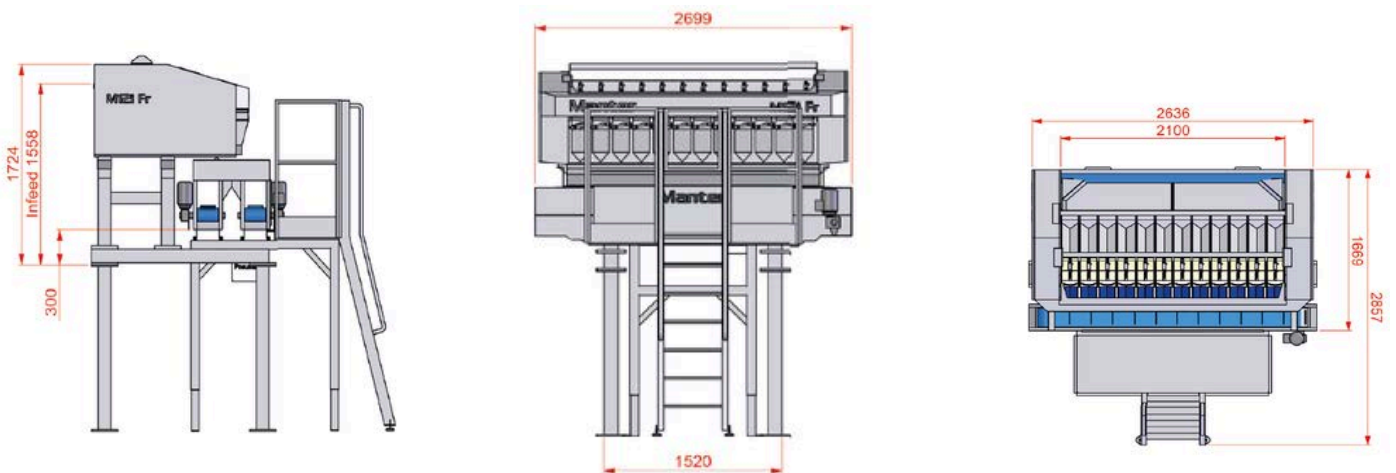

Manter International B.V.

Phileas Foggstraat 66
7825 AL Emmen
Países Bajos

Contacto

+31 591 626300
sales@manter.com
www.manter.com



M12i Fr

Waage



Die M12i Fr (Frozen) ist eine Mehrkopfwaage aus Edelstahl, speziell für die Tiefkühlkostindustrie entwickelt. Ideal für Verarbeiter von einzeln schockgefrosteten Produkten (IQF) sowie Fisch, Fleisch und Geflügel. Die M12i Fr bietet einen Wiegebereich von 250g bis 10kg und erreicht Geschwindigkeiten von bis zu 50 Abwürfen pro Minute.

Merkmale

- Ausgestattet mit 12 Wiegebehältern in Linie.
- Geeignet für das präzise Wiegen von frischen Produkten und tiefgefrorenen IQF-Lebensmitteln, einschließlich Fisch, Fleisch und Gemüse.
- Antihaft-beschichtetes Blech für verbesserten Produktfluss.
- Mehrere Austragskonfigurationen verfügbar.
- Kompatibel mit einer Vielzahl von Verpackungsmaschinen.
- Intuitive Touchscreen-Benutzeroberfläche für einfache Bedienung.

M12i Fr

Waage

| Spezifikationen | Werte |
|--|-------------------------------------|
| Wägebereich | 0,5 - 5 kg* |
| Kapazität bei 2,5 kg bis zu | 50 Abwürfe/Min* |
| Fassungsvermögen des Wiegekopfs | 9 Liter |
| IP-Schutzart | IP65 |
| Luftverbrauch (konditionierte Trockenluft) | 150 l/min |
| Versorgungsspannung | 3x400V/50Hz/N/GND - 3x220V/60Hz/GND |
| Stromverbrauch | 5,5 kW |
| Gewicht der Maschine | 2450 kg |

*Abhängig vom Produkt und vom Entladesystem.

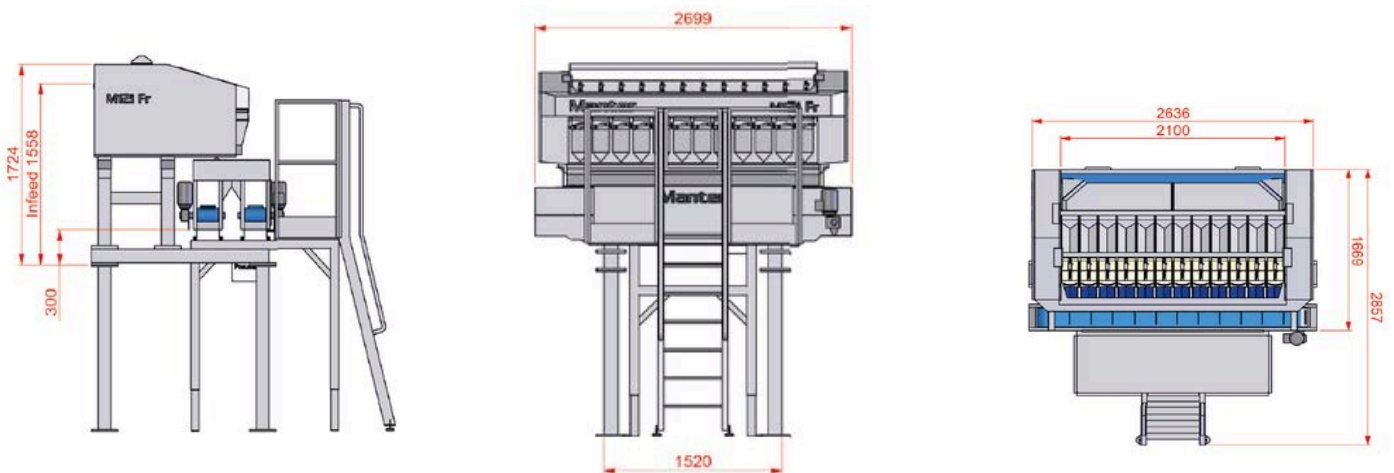

Manter International B.V.

Phileas Foggstraat 66
7825 AL Emmen,
Niederlande

Kontakt

+31 591 626300
sales@manter.com
www.manter.com



M12i Fr

Peseuses



La M12i Fr (Frozen) est une peseuse associative en acier inoxydable, spécialement conçue pour l'industrie des aliments surgelés. Idéale pour les transformateurs de produits individuellement congelés (IQF), ainsi que de poisson, viande et volaille. La M12i Fr offre une plage de pesage de 250g à 10kg et peut atteindre jusqu'à 50 chutes par minute.

Caractéristiques

- Équipée de 12 godets de pesage en ligne.
- Convient pour un pesage précis de produits frais et d'aliments surgelés IQF, y compris poisson, viande et légumes.
- Tôle avec motif antiadhésif pour améliorer l'écoulement du produit.
- Différentes configurations de décharge disponibles.
- Compatible avec une large gamme de machines d'emballage.
- Interface écran tactile intuitive pour une utilisation facile.

M12i Fr

Peseuses

| Caractéristiques | Valeurs |
|--|-------------------------------------|
| Plage de pesée | 0,5 - 5 kg* |
| Capacité de 2,5 kg jusqu'à | 50 déversements/min* |
| Capacité du godet | 9 litres |
| Indice de protection IP | IP65 |
| Consommation d'air (air sec conditionné) | 150 L/min |
| Tension d'alimentation | 3x400V/50Hz/N/GND - 3x220V/60Hz/GND |
| Consommation d'énergie | 5,5 kW |
| Poids de la machine | 2450 kg |

*Selon le produit et le système de refolement.

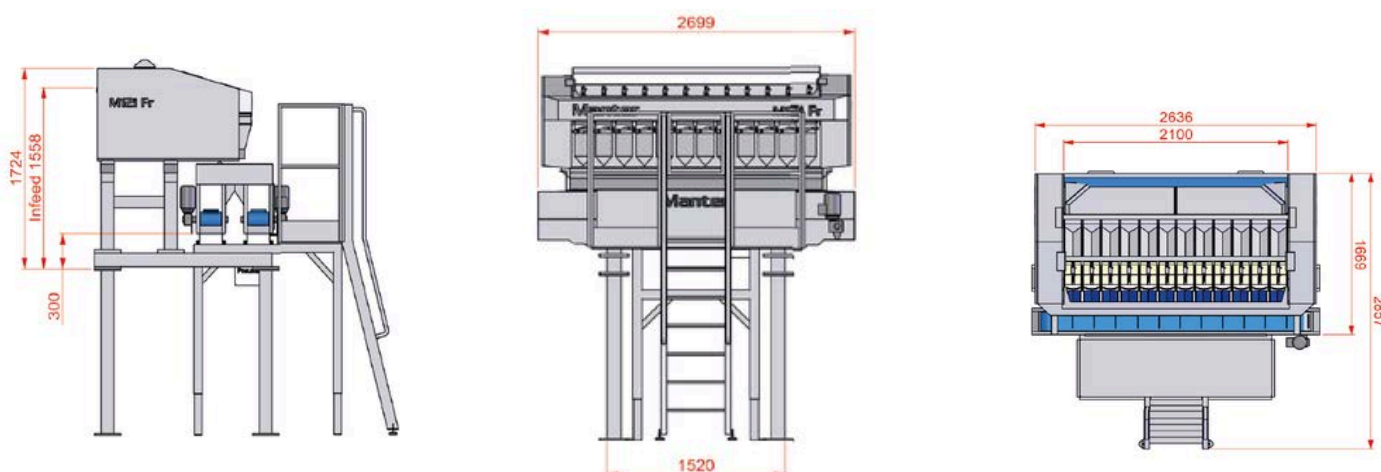

Manter International B.V.

Phileas Foggstraat 66
7825 AL Emmen Pays-
Bas

Contact

+31 591 626300
sales@manter.com
www.manter.com

