

Double Wicket Bagger

Packaging machine



The Double Wicket Bagger is designed to pack potatoes, fruits, onions, and dried foods into premade, wicketed bags at high speeds (up to 60 bags per minute). The Double Wicket Bagger makes a great addition to any facility interested in packing multiple consumer bags and changing the bag styles several times throughout the day. Also available in a single version.

Features

- Designed for use with closure locks and tape heads
- Dual filling capacity
- Suction cups to hold securely onto bag while filling
- Two crank arms to make easy adjustments when changing bag sizes
- Simple wicket design works with many types of bags, primarily poly and mesh

Double Wicket Bagger

Packaging machine

Specifications	Values
Packing range:	1 - 10 kg*
Bag width:	220 - 380 mm
Bag height:	400 - 690 mm
Capacity at 2.5kg up to:	56 bags/min*
IP-rating	IP54
Air consumption: (conditioned dry air)	400 L/min
Supply voltage	3x 400V/50Hz+N+GND / 3x220v60Hz+GND
Power consumption:	4.8 kW
Weight of the machine:	650 kg

*Depending on product, packaging type and other possible factors.

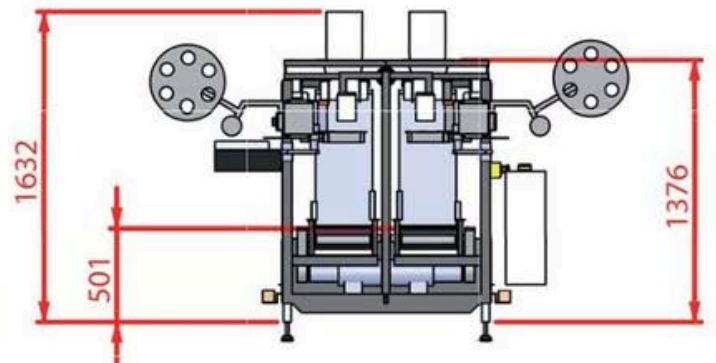
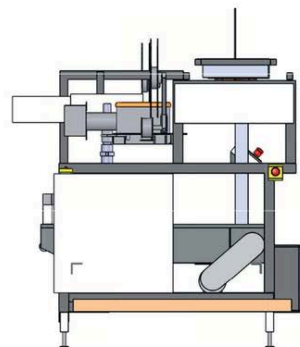
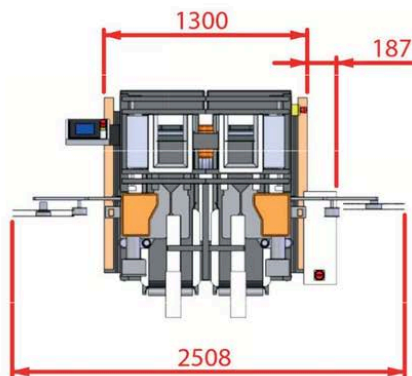

Manter International B.V.

Phileas Foggstraat 66
7825 AL Emmen
The Netherlands

Contact

+31 591 626300
sales@manter.com
www.manter.com



Double Wicket Bagger

Verpakkingsmachine



De dubbele wikkelzakmachine is ontworpen om aardappelen, fruit, uien en gedroogde voedingsmiddelen met hoge snelheid (tot 60 zakken per minuut) in voorgevormde zakken met wikkelingen te verpakken. De dubbele wikkelzakmachine is een waardevolle aanvulling voor elke faciliteit die meerdere consumentenzakken wil vullen en de zaktypen gedurende de dag meerdere keren wil wisselen. Ook verkrijgbaar in een uitvoering met enkele wikkeling.

Functies

- Ontworpen voor gebruik met sluitlocks en tape-koppen
- Dubbele vulcapaciteit
- Zuignappen om de zak tijdens het vullen stevig vast te houden
- Twee slingerarmen voor eenvoudige afstelling bij wisselen van zakformaten
- Eenvoudig wicket-ontwerp, geschikt voor diverse zaktypes, voornamelijk poly- en netzakken

Double Wicket Bagger

Verpakkingsmachine

Specificaties	Waarden
Verpakkingsbereik:	1 - 10 kg*
Zakbreedte	220 - 380 mm
Zakhoogte	400 - 690 mm
Capaciteit bij 2,5 kg tot:	56 zakken/min*
IP-classificatie	IP54
Luchtverbruik: (geconditioneerde droge lucht)	400 l/min
Voedingsspanning	3x 400V/50Hz+N+GND / 3x220v60Hz+GND
Stroomverbruik:	4,8 kW
Gewicht van de machine:	650 kg

*Afhankelijk van het product, het type verpakking en andere mogelijke factoren.

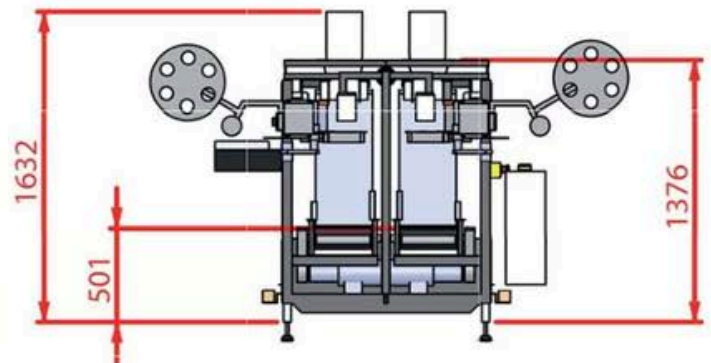
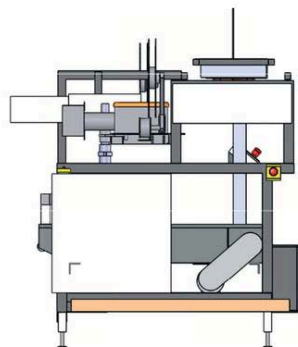
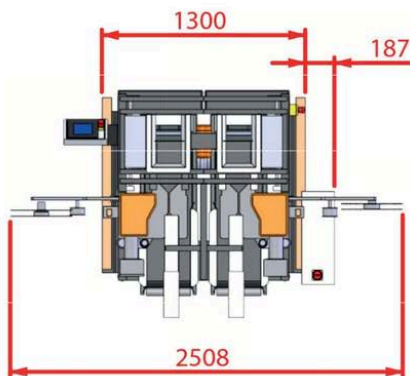

Manter International B.V.

Phileas Foggstraat 66
7825 AL Emmen
Nederland

Contact

+31 591 626300
sales@manter.com
www.manter.com



Double Wicket Bagger

Máquina de embalaje



La envasadora de doble puerta está diseñada para envasar papas, frutas, cebollas y alimentos secos en bolsas prefabricadas con puerta a alta velocidad (hasta 60 bolsas por minuto). Es una excelente incorporación para cualquier instalación que necesite envasar varias bolsas de consumo y cambiar el estilo de las bolsas varias veces al día. También disponible en una sola versión.

Características

- Diseñado para uso con cierres tipo lock y cabezales de cinta
- Capacidad de llenado doble
- Ventosas para sujetar firmemente la bolsa durante el llenado
- Dos manivelas para ajustes sencillos al cambiar tamaños de bolsa
- Diseño de wicket simple, compatible con muchos tipos de bolsas, principalmente de polietileno y malla



Double Wicket Bagger

Máquina de embalaje

Presupuesto	Valores
Rango de embalaje:	1 - 10 kg*
Ancho de la bolsa:	220 - 380 mm
Altura de la bolsa:	400 - 690 mm
Capacidad de 2,5 kg hasta:	56 bolsas/min*
Clasificación IP	IP54
Consumo de aire: (aire seco acondicionado)	400 L/min
Tensión de alimentación	3x 400V/50Hz+N+GND / 3x220v60Hz+GND
Consumo de energía:	4,8 kW
Peso de la máquina:	650 kilos

*Dependiendo del producto, tipo de embalaje y otros posibles factores.

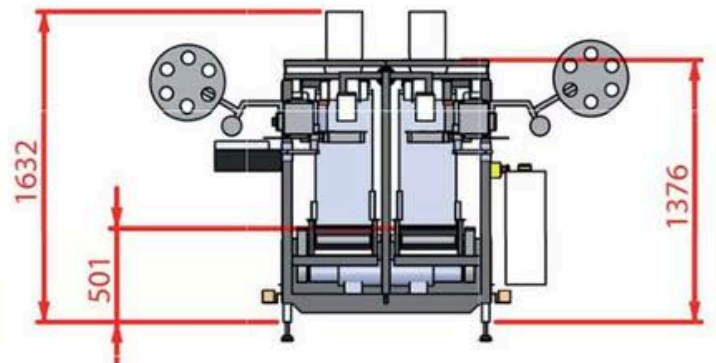
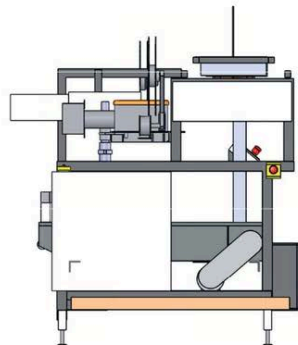
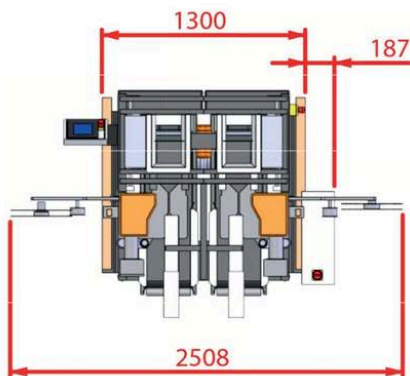

Manter International B.V.

Phileas Foggstraat 66
7825 AL Emmen
Países Bajos

Contacto

+31 591 626300
sales@manter.com
www.manter.com





Double Wicket Bagger

Verpackungsmaschine



Die Doppelwicket-Absackmaschine ist für das schnelle Verpacken von Kartoffeln, Obst, Zwiebeln und Trockenlebensmitteln in vorgefertigte, mit Wicket versehene Beutel konzipiert (bis zu 60 Beutel pro Minute). Sie ist die ideale Ergänzung für jeden Betrieb, der regelmäßig verschiedene Verbraucherbeutel verpacken und die Beutelarten mehrmals täglich wechseln möchte. Auch als Einzelversion erhältlich.

Merkmale

- Entwickelt für die Verwendung mit Verschluss-Locks und Tape-Köpfen
- Doppelte Füllkapazität
- Saugnäpfe zum sicheren Fixieren des Beutels während des Befüllens
- Zwei Kurbeln für einfache Anpassungen beim Wechsel der Beutelgrößen
- Einfaches Wicket-Design, geeignet für viele Beuteltypen, hauptsächlich Poly- und Netzbeutel



Double Wicket Bagger

Verpackungsmaschine

Spezifikationen	Werte
Verpackungsbereich:	1 - 10 kg*
Taschenbreite:	220 - 380 mm
Taschenhöhe:	400 - 690 mm
Kapazität bei 2,5 kg bis zu:	56 Säcke/min*
IP-Schutzart	IP54
Luftverbrauch: (konditionierte Trockenluft)	400 l/min
Versorgungsspannung	3x 400V/50Hz+N+GND / 3x220v60Hz+GND
Stromverbrauch:	4,8 kW
Gewicht der Maschine:	650 kg

*Abhängig vom Produkt, der Verpackungsart und anderen möglichen Faktoren.

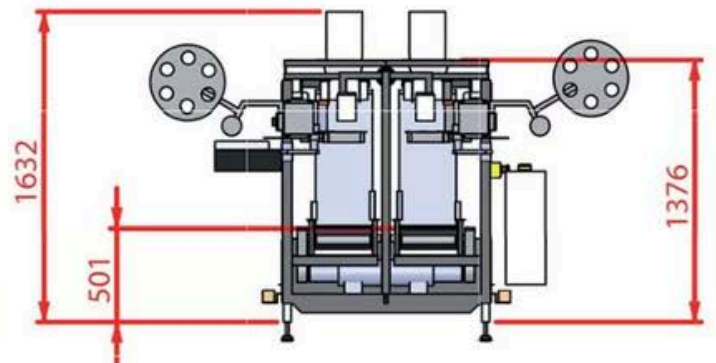
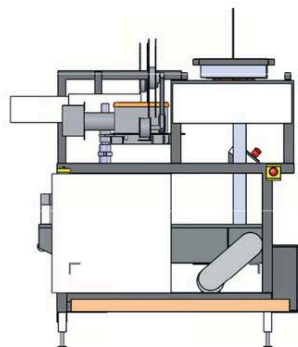
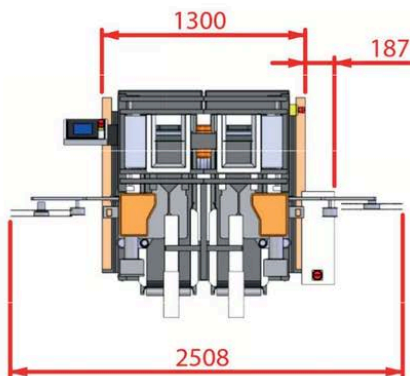

Manter International B.V.

Phileas Foggstraat 66
7825 AL Emmen
Die Niederlande

Kontakt

+31 591 626300
sales@manter.com
www.manter.com



Double Wicket Bagger

Machine d'emballage



L'ensacheuse à double anse est conçue pour conditionner à grande vitesse (jusqu'à 60 sacs par minute) pommes de terre, fruits, oignons et aliments secs dans des sacs préformés à anse. Elle constitue un atout précieux pour toute installation souhaitant conditionner différents types de sacs destinés aux consommateurs et en changer plusieurs fois par jour. Également disponible en version simple.

Caractéristiques

- Conçu pour une utilisation avec fermetures lock et têtes de ruban
- Capacité de remplissage double
- Ventouses pour maintenir fermement le sac pendant le remplissage
- Deux manivelles pour des réglages faciles lors du changement de formats de sacs
- Conception simple à wicket, compatible avec de nombreux types de sacs, principalement en polyéthylène et en maille



Double Wicket Bagger

Machine d'emballage

Caractéristiques	Valeurs
Gamme d'emballage :	1 à 10 kg*
Largeur du sac :	220 - 380 mm
Hauteur du sac :	400 - 690 mm
Capacité à 2,5 kg jusqu'à :	56 sacs/min*
Indice de protection IP	IP54
Consommation d'air : (air sec conditionné)	400 L/min
Tension d'alimentation	3x 400V/50Hz+N+GND / 3x220v60Hz+GND
Consommation électrique :	4,8 kW
Poids de la machine :	650 kg

*Selon le produit, le type d'emballage et d'autres facteurs possibles.

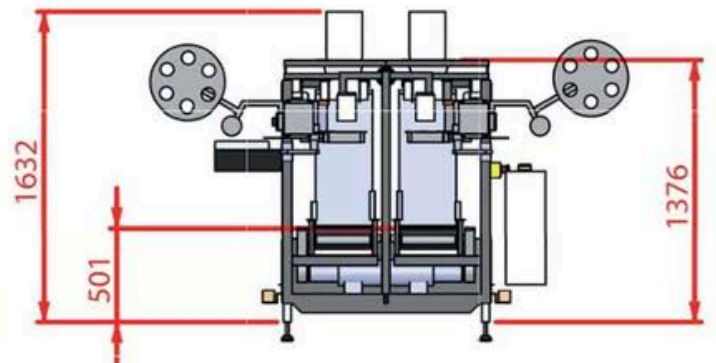
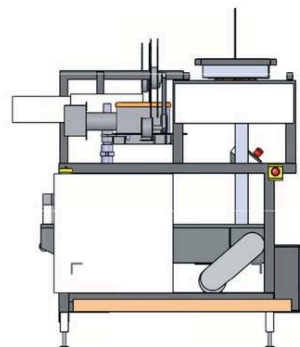
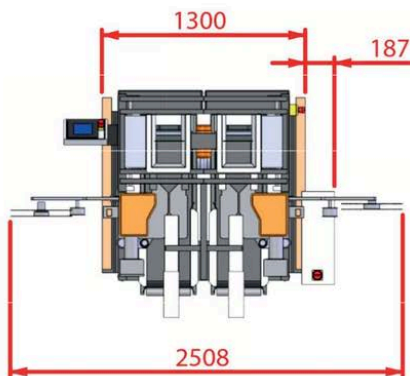

Manter International B.V.

Phileas Foggstraat 66
7825 AL Emmen
Les Pays-Bas

Contact

+31 591 626300
sales@manter.com
www.manter.com

