

Double Wicket Bagger Ca

Packaging machine



The Wicket Bagger Ca is specifically designed for packing carrots, parsnips and other long vegetables in pre-made wicket bags. The Wicket Bagger can be equipped with a shaking unit to remove the carrots from the lines and is available with a tape or Kwik Lok closing unit. This machine is available in single and double (Double Wicket Bagger Ca) versions. This machine is available in single and double (Double Wicket Bagger Ca) versions.

Features

- Designed for use with closure locks and tape heads
- Dual filling capacity
- Suction cups to hold securely onto bag while filling
- Two crank arms to make easy adjustments when changing bag sizes
- Simple wicket design works with many types of bags, primarily poly and mesh

Double Wicket Bagger Ca

Packaging machine

Specifications	Values
Packing range	0.5 - 5 kg*
Bag width	220 - 380 mm
Bag height	400 - 690 mm
Capacity at 2.5kg up to	32 bags/min*
IP-rating	IP54
Air consumption (conditioned dry air)	400 L/min
Supply voltage	3x 400V/50Hz+N+GND / 3x220v60Hz+GND
Power consumption	4.8 kW
Weight of the machine	650 kg

*Depending on product, packaging type and other possible factors.

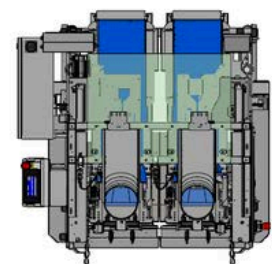
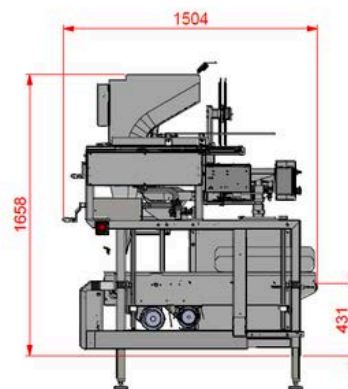
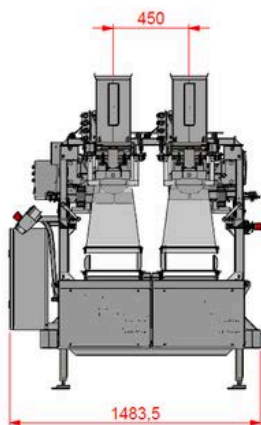

Manter International B.V.

Phileas Foggstraat 66
7825 AL Emmen
The Netherlands

Contact

+31 591 626300
sales@manter.com
www.manter.com





Double Wicket Bagger Ca

Verpakkingsmachine



De Wicket Bagger Ca is specifiek ontworpen om wortelen, penen, pastinaak en andere lange groenten mee te verpakken in voorgemaakte wicketzakken. De Wicket Bagger kan worden uitgerust met een schudeenheid om de wortelen uit de lijnen en is verkrijgbaar met een tape- of Kwik Lok-sluiteenheid. Deze machine is verkrijgbaar in enkele en dubbele (Double Wicket Bagger Ca) uitvoering.

Functies

- Ontworpen voor gebruik met sluitlocks en tape-units
- Dubbele vulcapaciteit
- Zuignappen om de zak stevig vast te houden tijdens het vullen
- Twee slingerarmen voor eenvoudige afstelling bij wisselen van zakformaten
- Eenvoudig wicket-ontwerp, geschikt voor diverse zaktypes, voornamelijk poly- en netzakken



Double Wicket Bagger Ca

Verpakkingsmachine

Specificaties	Waarden
Verpakkingsbereik	0,5 - 5 kg*
Zakbreedte	220 - 380 mm
Zakhoogte	400 - 690 mm
Capaciteit bij 2,5 kg tot	32 zakken/min*
IP-classificatie	IP54
Luchtverbruik (geconditioneerde droge lucht)	400 L/min
Voedingsspanning	3x 400V/50Hz+N+GND / 3x220v60Hz+GND
Stroomverbruik	4,8 kW
Gewicht van de machine	650 kg

*Afhankelijk van het product, het type verpakking en andere mogelijke factoren.

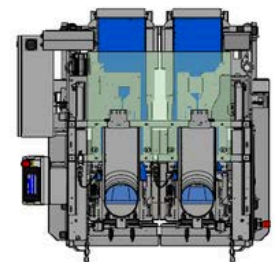
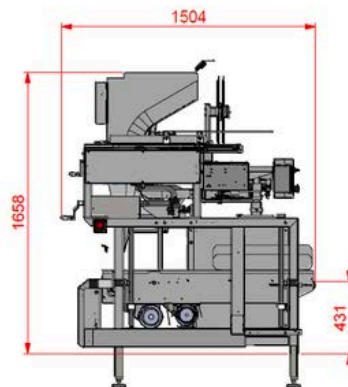
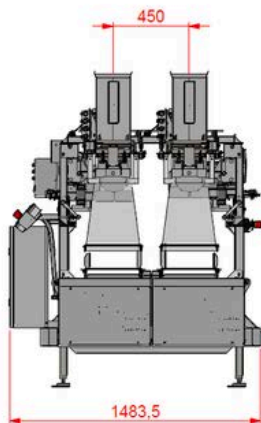

Manter International B.V.

Phileas Foggstraat 66
7825 AL Emmen
Nederland

Contact

+31 591 626300
sales@manter.com
www.manter.com



Double Wicket Bagger Ca

Máquina de embalaje



La Wicket Bagger Ca ha sido especialmente diseñada para envasar zanahorias, penes, chirivías y otras hortalizas largas en bolsas prefabricadas tipo wicket. La máquina puede equiparse con una unidad vibradora para alinear las zanahorias provenientes de la línea de producción y está disponible con sistema de cierre de cinta adhesiva o Kwik Lok. Esta máquina se ofrece tanto en versión simple como doble (Double Wicket Bagger Ca).

Características

- Diseñado para uso con cierres tipo lock y unidades de cinta
- Capacidad de llenado doble
- Ventosas para sujetar firmemente la bolsa durante el llenado
- Dos manivelas para ajustes sencillos al cambiar tamaños de bolsa
- Diseño de wicket simple, compatible con muchos tipos de bolsas, principalmente de polietileno y malla



Double Wicket Bagger Ca

Máquina de embalaje

Presupuesto	Valores
Gama de embalaje	0,5 - 5 kg*
Ancho de la bolsa	220 - 380 mm
Altura de la bolsa	400 - 690 mm
Capacidad a 2,5 kg hasta	32 bolsas/min*
Clasificación IP	IP54
Consumo de aire (aire seco acondicionado)	400 L/min
Tensión de alimentación	3x 400V/50Hz+N+GND / 3x220v60Hz+GND
Consumo de energía	4,8 kW
Peso de la máquina	650 kg

*Dependiendo del producto, el tipo de embalaje y otros factores posibles.

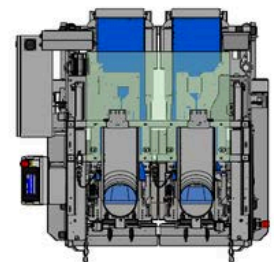
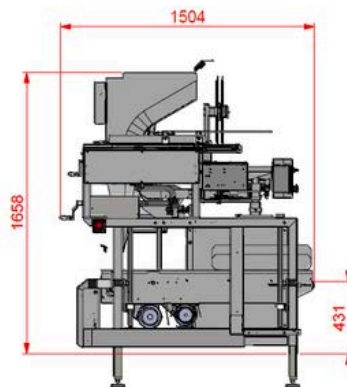
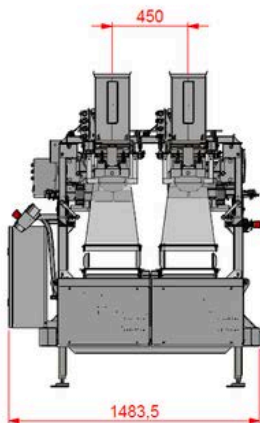

Manter International B.V.

Phileas Foggstraat 66
7825 AL Emmen
Países Bajos

Contacto

+31 591 626300
sales@manter.com
www.manter.com





Double Wicket Bagger Ca

Verpackungsmaschine



Die Wicket Bagger Ca wurde speziell zum Verpacken von Karotten, Pastinaken und anderem länglichen Gemüse in vorgefertigte Wicket Bags entwickelt. Die Wicket Bagger kann mit einer Rüttleinheit zum Entfernen der Karotten aus den Fäden ausgestattet werden und ist mit einem Klebeband- oder Kwik-Lok-Verschlusssystem erhältlich. Diese Maschine ist als Einzel- und Doppelversion (Double Wicket Bagger Ca) verfügbar.

Merkmale

- Entwickelt für die Verwendung mit Verschluss-Locks und Tape-Einheiten
- Doppelte Füllkapazität
- Saugnäpfe zum sicheren Fixieren des Beutels während des Befüllens
- Zwei Kurbeln für einfache Anpassungen beim Wechsel der Beutelgrößen
- Einfaches Wicket-Design, geeignet für viele Beuteltypen, hauptsächlich Poly- und Netzbeutel



Double Wicket Bagger Ca

Verpackungsmaschine

Spezifikationen	Werte
Verpackungsbereich	0,5 - 5 kg*
Beutelbreite	220 - 380 mm
Beutelhöhe	400 - 690 mm
Kapazität bei 2,5 kg bis zu	32 Säcke/min*
IP-Schutzart	IP54
Luftverbrauch (konditionierte Trockenluft)	400 l/min
Versorgungsspannung	3x 400V/50Hz+N+GND / 3x220v60Hz+GND
Leistungsaufnahme	4,8 kW
Gewicht der Maschine	650 kg

*Abhängig vom Produkt, der Verpackungsart und anderen möglichen Faktoren.

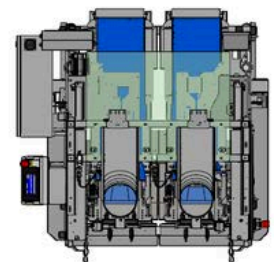
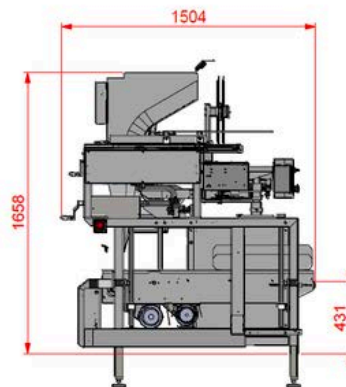
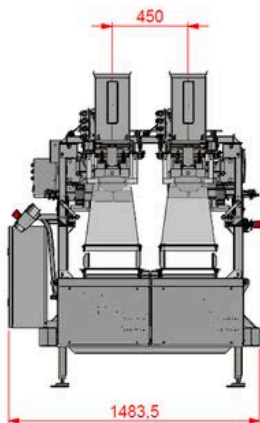

Manter International B.V.

Phileas Foggstraat 66
7825 AL Emmen
Niederlande

Kontakt

+31 591 626300
sales@manter.com
www.manter.com





Double Wicket Bagger Ca

Machine d'emballage



L'ensacheuse à sacs Wicket Bagger Ca est spécialement conçue pour le conditionnement des carottes, panais et autres légumes longs dans des sacs à sacs préformés. Elle peut être équipée d'un système de secouage pour détacher les carottes des lignes et est disponible avec un système de fermeture à ruban ou Kwik Lok. Cette machine existe en versions simple et double (Double Wicket Bagger Ca).

Caractéristiques

- Conçu pour une utilisation avec fermetures lock et unités de ruban
- Capacité de remplissage double
- Ventouses pour maintenir fermement le sac pendant le remplissage
- Deux manivelles pour des réglages faciles lors du changement de formats de sacs
- Conception simple à wicket, compatible avec de nombreux types de sacs, principalement en polyéthylène et en maille

Double Wicket Bagger Ca

Machine d'emballage

Caractéristiques:	Valeurs
Gamme d'emballage	0,5 - 5 kg*
Largeur du sac	220 - 380 mm
Hauteur du sac	400 - 690 mm
Capacité à 2,5 kg jusqu'à	32 sacs/min*
Indice de protection IP	IP54
Consommation d'air (air sec conditionné)	400 L/min
Tension d'alimentation	3x 400V/50Hz+N+GND / 3x220v60Hz+GND
Consommation électrique	4,8 kW
Poids de la machine	650 kg

*Selon le produit, le type d'emballage et d'autres facteurs possibles.

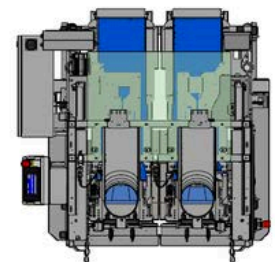
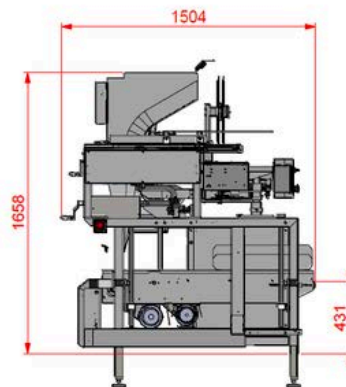
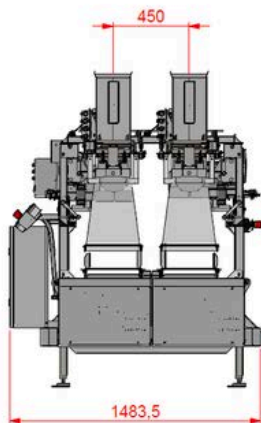

Manter International B.V.

Phileas Foggstraat 66
7825 AL Emmen
Les Pays-Bas

Contact

+31 591 626300
sales@manter.com
www.manter.com

