

# 16000 Mix

Weighing machine

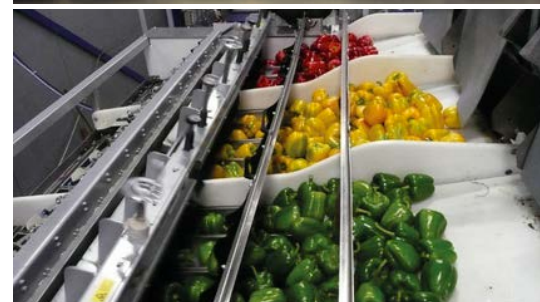

The 16000 Mix is a multihead weigher specially designed for weighing and counting three different colors of bell peppers for traffic-light style packaging. The weigher features 16 buckets divided into three groups of 5, 5, and 6 buckets, with each group handling a different color. The 16000 Mix can achieve speeds of up to 55 drops per minute.

## Features

- Equipped with 16 dosing and weighing buckets, divided into 3 groups of 5, 5, and 6.
- Designed to weigh and count a combination, such as a three-color pepper mix.
- Various discharge systems are available.
- Can be combined with a wide range of packaging machines.
- Intuitive touchscreen interface for easy operation.

# 16000 Mix

Weighing machine

Specifications	Values
Weighing range	0.25 - 3 kg*
Capacity at 2.5kg up to	55 drops/min*
Capacity of the bucket	3.5 ltr
IP-rating	IP54
Air consumption (conditioned dry air)	150 L/min
Supply voltage	3×400V/50Hz/N/GND - 3×220V/60Hz/GND
Power consumption	5.5 kW
Weight of the machine	2450 kg

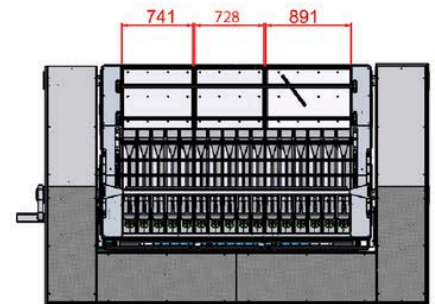
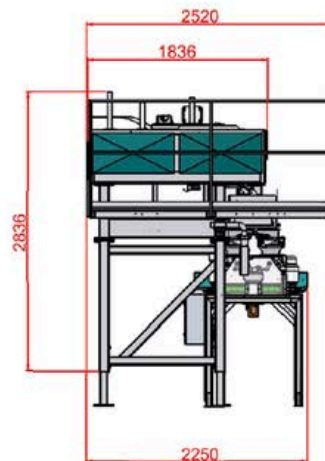
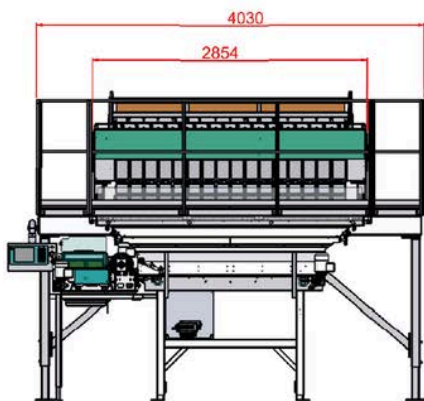

## Manter International B.V.

Phileas Foggstraat 66  
7825 AL Emmen  
The Netherlands

## Contact

+31 591 626300  
sales@manter.com  
www.manter.com



# 16000 Mix

Weegmachine



De 16000 Mix is een combinatieweger, speciaal ontwikkeld voor het wegen en tellen van drie verschillende kleuren paprika's voor stoplichtverpakkingen. De weger beschikt over 16 weegbakken verdeeld in drie groepen van 5, 5 en 6 bakken, waarbij elke groep een andere kleur paprika verwerkt. De 16000 Mix kan snelheden bereiken van tot 55 stortingen per minuut.

## Funcities

- Uitgerust met 16 doseer- en weegbakken, verdeeld in 3 groepen van 5, 5 en 6.
- Ontworpen voor het wegen en tellen van combinaties, zoals een mix van drie kleuren paprika's.
- Verschillende lossingssystemen beschikbaar.
- Combinaties met een breed scala aan verpakkingsmachines mogelijk.
- Intuïtieve touchscreeninterface voor eenvoudige bediening.
-

# 16000 Mix

Weegmachine

Specificaties	Waarden
Weegbereik	0,25 - 3 kg*
Capaciteit bij 2,5 kg tot	55 stortingen/min*
Inhoud van de weegbak	3,5 liter
IP-classificatie	IP54
Luchtverbruik (geconditioneerde droge lucht)	150 l/min
Voedingsspanning	3×400V/50Hz/N/GND - 3×220V/60Hz/GND
Stroomverbruik	5,5 kW
Gewicht van de machine	2450 kg

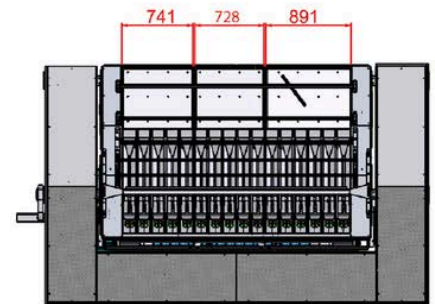
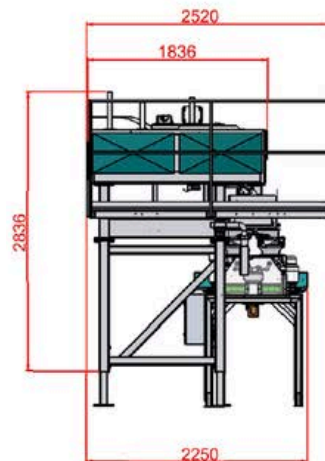
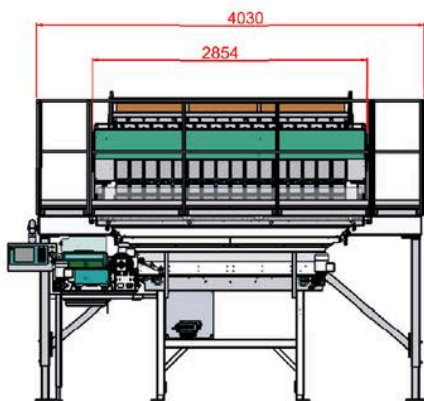

## Manter International B.V.

Phileas Foggstraat 66  
7825 AL Emmen  
Nederland

## Contact

+31 591 626300  
sales@manter.com  
www.manter.com



# 16000 Mix

Pesadoras

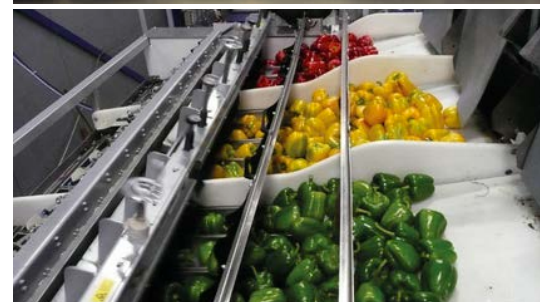

La 16000 Mix es una pesadora multicabezal especialmente diseñada para pesar y contar tres colores diferentes de pimientos para envases estilo semáforo. La pesa cuenta con 16 cangilones divididas en tres grupos de 5, 5 y 6 cangilones, con cada grupo manejando un color diferente. La 16000 Mix puede alcanzar velocidades de hasta 55 descargas por minuto.

## Características

- Equipada con 16 cangilones de pesaje y dosificación, divididos en 3 grupos de 5, 5 y 6.
- Diseñada para pesar y contar combinaciones, como una mezcla de pimientos de tres colores.
- Diversos sistemas de descarga disponibles.
- Posibilidad de combinación con una amplia gama de máquinas de envasado.
- Interfaz de pantalla táctil intuitiva para un manejo sencillo.



## 16000 Mix

Pesadoras

### Presupuesto

### Valores

Rango de pesaje	0,25 - 3 kg*
Capacidad de 2,5 kg hasta	55 descargas/min*
Capacidad de los cangilones	3,5 litros
Clasificación IP	IP54
Consumo de aire (aire seco acondicionado)	150 L/min
Tensión de alimentación	3x400V/50Hz/N/GND - 3x220V/60Hz/GND
Consumo de energía	5,5 kW
Peso de la máquina	2450 kg

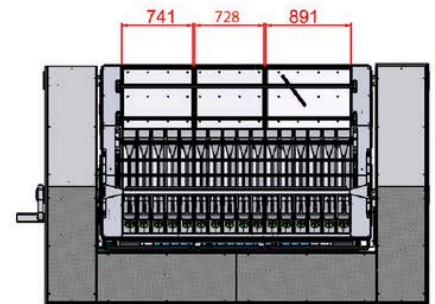
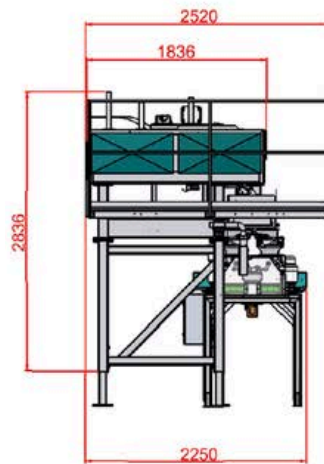
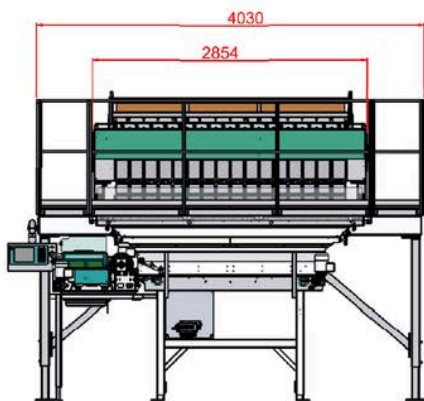

### Manter International B.V.

Phileas Foggstraat 66  
7825 AL Emmen  
Países Bajos

### Contacto

+31 591 626300  
sales@manter.com  
www.manter.com



# 16000 Mix

Waage



Die 16000 Mix ist eine Mehrkopfwage, speziell für das Wiegen und Zählen von drei verschiedenen Paprikafarben für Ampelverpackungen entwickelt. Die Waage verfügt über 16 Wiegebakel, aufgeteilt in drei Gruppen von 5, 5 und 6 Bakeln, wobei jede Gruppe eine andere Farbe verarbeitet. Die 16000 Mix erreicht Geschwindigkeiten von bis zu 55 Abwürfen pro Minute.

## Merkmale

- Ausgestattet mit 16 Dosier- und Wiegebehältern, aufgeteilt in 3 Gruppen von 5, 5 und 6.
- Entwickelt zum Wiegen und Zählen von Kombinationen, wie z. B. einer Dreifarbpaprika-Mischung.
- Verschiedene Austragsysteme verfügbar.
- Kombination mit einer Vielzahl von Verpackungsmaschinen möglich.
- Intuitive Touchscreen-Benutzeroberfläche für einfache Bedienung.

# 16000 Mix

Waage

## Spezifikationen

## Werte

Wägebereich	0,25 - 3 kg*
Kapazität bei 2,5 kg bis zu	55 Abwürfe/Min*
Fassungsvermögen des Wiegekopfs	3,5 Liter
IP-Schutzart	IP54
Luftverbrauch (konditionierte Trockenluft)	150 l/min
Versorgungsspannung	3×400V/50Hz/N/GND - 3×220V/60Hz/GND
Stromverbrauch	5,5 kW
Gewicht der Maschine	2450 kg

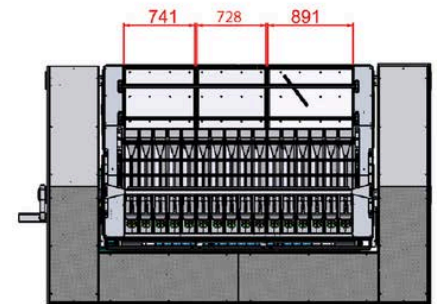
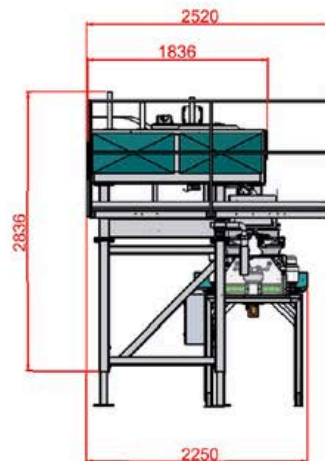
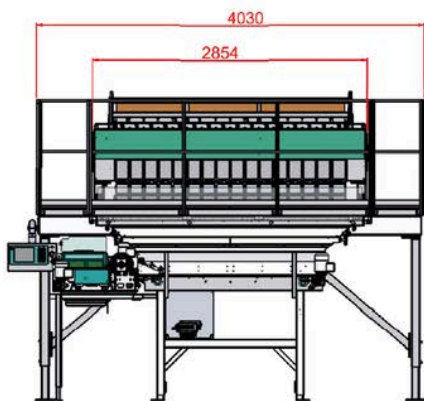

## Manter International B.V.

Phileas Foggstraat 66  
7825 AL Emmen  
Niederlande

## Kontakt

+31 591 626300  
sales@manter.com  
www.manter.com



# 16000 Mix

Peseuses



La 16000 Mix est une peseuse associative spécialement conçue pour peser et compter trois couleurs différentes de poivrons pour des emballages style feu tricolore. La peseuse dispose de 16 godets répartis en trois groupes de 5, 5 et 6 godets, chaque groupe traitant une couleur différente. La 16000 Mix peut atteindre des vitesses allant jusqu'à 55 déversements par minute.

## Caractéristiques

- Équipée de 16 godets de dosage et de pesage, répartis en 3 groupes de 5, 5 et 6.
- Conçue pour peser et compter des combinaisons, comme un mélange de poivrons de trois couleurs.
- Différents systèmes de décharge possibles.
- Combinaison possible avec une large gamme de machines d'emballage.
- Interface écran tactile intuitive pour une utilisation facile.

# 16000 Mix

Peseuses

Caractéristiques	Valeurs
Plage de pesée	0,25 - 3 kg*
Capacité de 2,5 kg jusqu'à	55 déversements/min*
Capacité du godet	3,5 litres
Indice de protection IP	IP54
Consommation d'air (air sec conditionné)	150 L/min
Tension d'alimentation	3x400V/50Hz/N/GND - 3x220V/60Hz/GND
Consommation d'énergie	5,5 kW
Poids de la machine	2450 kg

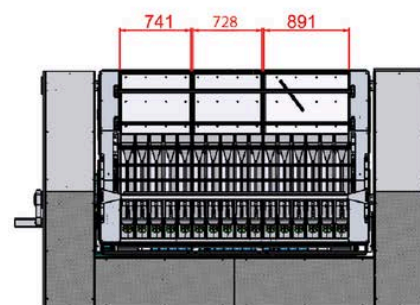
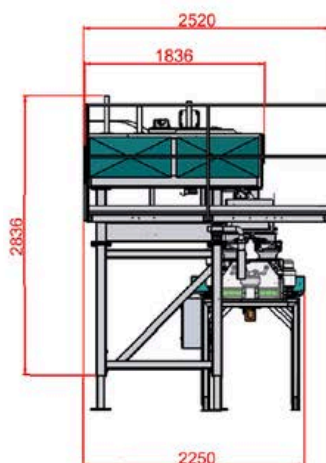
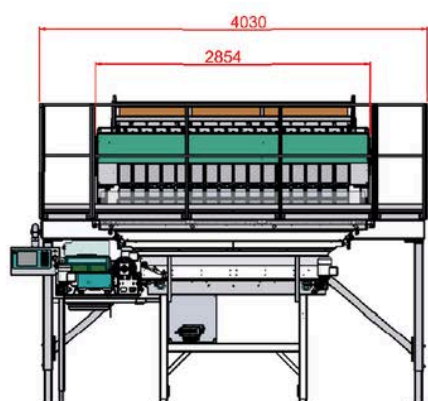

## Manter International B.V.

Phileas Foggstraat 66  
7825 AL Emmen  
Pays-Bas

## Contact

+31 591 626300  
sales@manter.com  
www.manter.com

