

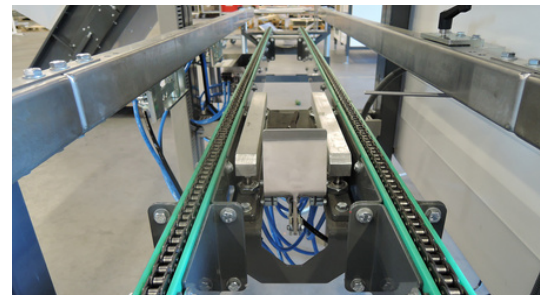

# Carton Filler

Packaging machine

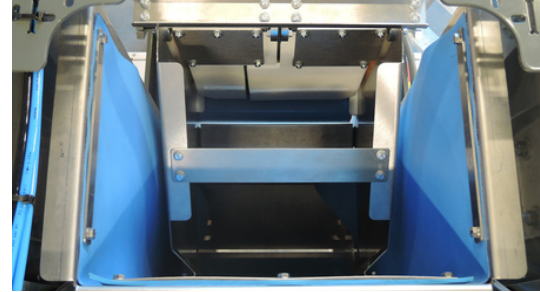

## NL

- Automatische verpakker voor het vullen van kratten en dozen.
- Dozen/kratten worden handmatig geplaatst en automatisch gevuld.
- Voorzien van bucket die omlaag in de doos zakt om de val van het product tijdens het vullen te reduceren.
- Te combineren met iedere weger.
- Eenvoudige bediening middels touchscreen.

## DE

- Automatisch füllen von Kisten oder Karton.
- Kist/Karton werden handmassig platziert und automatisch befüllt.
- Ausgeführt mit einem Zwischenkorb, der in der Kiste abgesenkt wird, um fallhöhe und impact zu reduzieren wenn befüllt wird.
- Zu kombinieren mit jede Waage.
- Zu bedienen mit Touchscreen.

## EN

- Automatic packer for filling crates or boxes.
- Boxes/crates are placed manually but closed and transported automatically.
- Equipped with an intermediate bin that is lowered down in the box to reduce drop and impact during filling.
- To combine with every weigher.
- User friendly touchscreen.



## Carton Filler

Packaging machine

NL Specificaties:	DE Spezifikationen:	EN Specifications:	
Verpakkingsbereik:	Verpackungsbereich:	Packing range:	<b>10 - 25 kg*</b>
Kratbreedte:	Breite des Kiste:	Crate width:	<b>450(L) x 305(W) x 180(H) mm</b>
Krathoogte:	Höhe des Kiste:	Crate height:	<b>600(L) x 450(W) x 305(H) mm</b>
Capaciteit bij 25kg tot	Leistung mit 25kg bis zu:	Capacity at 25kg up to:	<b>14 boxes/min*</b>
IP-beschermingsklasse	IP-Schutzklasse	IP-rating	<b>IP54</b>
Lucht consumptie: (geconditioneerde droge lucht)	Luftverbrauch: (konditionierte trockene Luft)	Air consumption: (conditioned dry air)	<b>200 L/min</b>
Voedingsspanning:	Spannungsdaten:	Supply voltage	<b>3 x 400V/50Hz+N+GND</b>
Stroomverbruik:	Anschlusswert:	Powerconsumption:	<b>1.5 kW</b>
Gewicht van de machine:	Gewicht der Maschine:	Weight of the machine:	<b>650 kg</b>

\* Afhankelijk van product.  
Abhängig von Produkt.  
Depends on product.

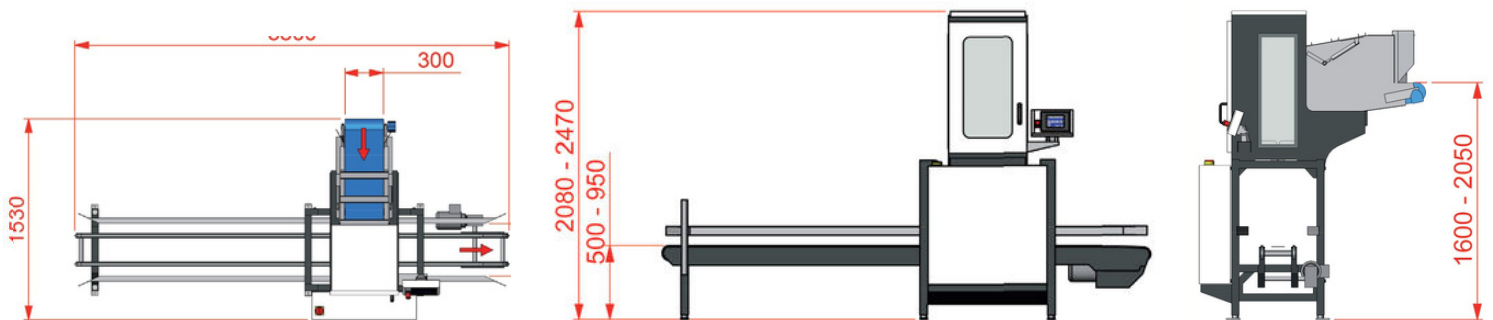

### Manter International B.V.

P.O. Box 2124 NL  
7801 CC Emmen  
The Netherlands

### Office

Phileas Foggstraat  
66 7825 AL Emmen  
The Netherlands

### Contact

+31 591 626300  
sales@manter.com  
www.manter.com

