

AutoPack

Packaging machine

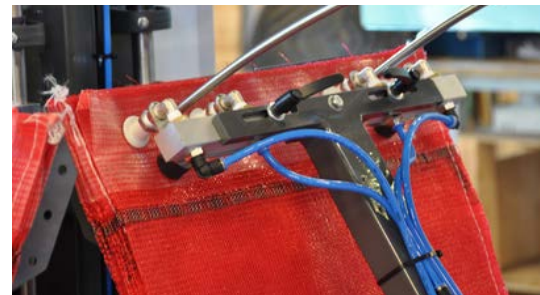

NL

- Automatische verpakker voor enkele net-, jute- en papieren zakken.
- Een combinatie van de Bagplacer en de SemiPack
- Verschillende extra sluitopties mogelijk zoals Hamer of Kwiklok.
- Te combineren met alle weegmachines.
- Eenvoudige bediening middels touchscreen.

DE

- Automatisch Verpacker für einzelne Säcken.
- Kombination von die Bagplacer und die SemiPack.
- Verschiedene schliessmöglichkeiten wie Hamer oder Kwiklok.
- Zu kombinieren mit allen Arten Wiegenmaschinen.
- Zu bedienen mit Touchscreen.

EN

- Automatic bagger for single net-, hessian and paper bags.
- A combination of the Bagplacer and the SemiPack
- Different closing options possible like hamer or kwiklok.
- To combine with all kinds of weighing systems.
- User friendly touchscreen.

AutoPack

Packaging machine

NL Specificaties:	DE Spezifikationen:	EN Specifications:	
Verpakkingsbereik:	Verpackungsbereich:	Packing range:	5 - 25 kg*
Zakbreedte	Breite des Beutels:	Bag width:	315 - 540 mm
Zakhoogte	Höhe des Beutels:	Bag height:	560 - 870 mm
IP-beschermingsklasse	IP-Schutzklasse	IP-rating	IP54
Capaciteit bij 25kg tot:	Leistung bei 25kg bis zu:	Capacity at 25kg up to:	15 bags/min*
Lucht consumptie: (geconditioneerde droge lucht)	Luftverbrauch: (konditionierte trockene Luft)	Air consumption: (conditioned dry air)	300 L/min
Voedingsspanning:	Spannungsdaten:	Supply voltage	3x 400V/50Hz+N+GND
Stroomverbruik:	Anschlusswert:	Powerconsumption:	8.7 kW
Gewicht van de machine:	Gewicht der Maschine:	Weight of the machine:	1850 kg

* Afhankelijk van product.
Abhängig von Produkt.
Depends on product.

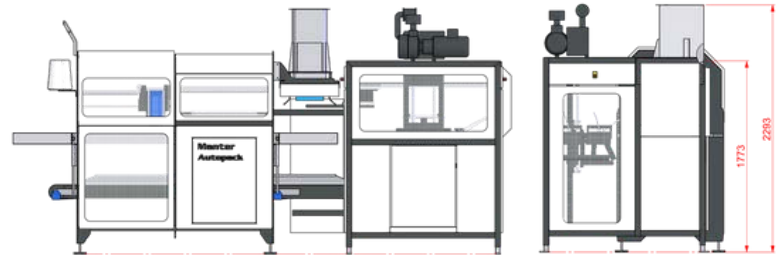
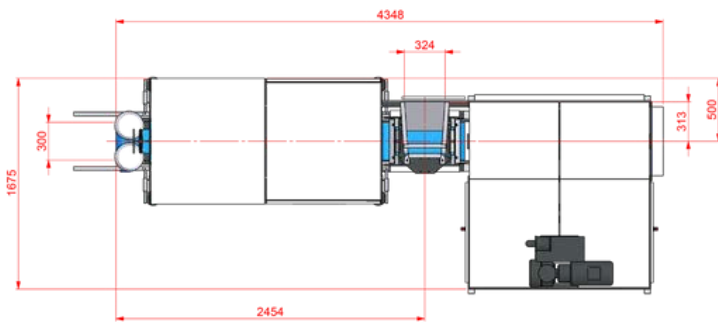

Manter International B.V.

P.O. Box 2124 NL
7801 CC Emmen
The Netherlands

Office

Phileas Foggstraat
66 7825 AL Emmen
The Netherlands

Contact

+31 591 626300
sales@manter.com
www.manter.com

