

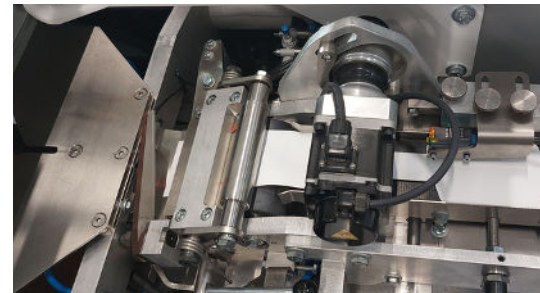

MoNo Clipper

Packaging machine



NL

- Verpakkingsmachine voor buisvormig net afgesloten met een seal middels een PE label
- Monomateriaal zakjes die eenvoudig te recyclen zijn
- Automatisch wisselen tussen 2 buizen met netmateriaal
- Uitgerust met een label feeder voor wijnglas- of seal-to-seal labels
- Gebruiksvriendelijk touchscreen

DE

- Verpackungsmaschine für Schlauchnetze, die mit einem PE-Etikett verschlossen werden
- Beutel aus Monomaterial, die leicht zu recyceln sind
- Automatischer Wechsel zwischen 2 Röhren mit Netzmaterial
- Ausgestattet mit einem Etiketteneinzug für Weinglas- oder Seal-to-Seal-Etiketten
- Benutzerfreundliches Touchscreen

EN

- Packaging machine for tubular net closed with a seal using a PE label
- Monomaterial bags that are easy to recycle
- Automatically switch between 2 tubes with net material
- Equipped with a label feeder for wine glass or seal-to-seal labels
- User-friendly touchscreen

MoNo Clipper

Packaging machine

NL Specificaties:	DE Spezifikationen:	EN Specifications:	
Verpakkingsbereik:	Verpackungsbereich:	Packing range:	0.25 - 2 kg*
Diameter netbuis	Durchmesser Netzrohr	Diametre nettube:	160 - 200 (default)
Capaciteit bij 1kg tot:	Leistung bei 1kg bis zu:	Capacity at 1kg up to:	30 bags/min*
Lucht consumptie: (geconditioneerde droge lucht)	Luftverbrauch: (konditionierte trockene Luft)	Air consumption: (conditioned dry air)	200 L/min
IP-beschermingsklasse	IP-Schutzklasse	IP-rating	IP54
Voedingsspanning:	Spannungsdaten:	Supply voltage	3x 400V/50Hz+N+GND
Stroomverbruik:	Anschlusswert:	Powerconsumption:	4 kW
Gewicht van de machine:	Gewicht der Maschine:	Weight of the machine:	650 kg

* Afhankelijk van product.
Abhängig von Produkt.
Depends on product.

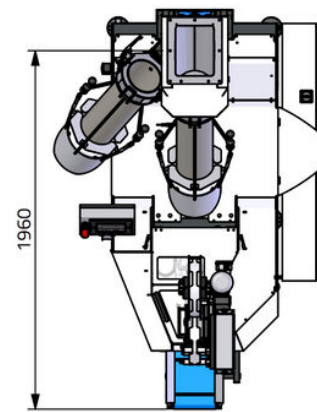
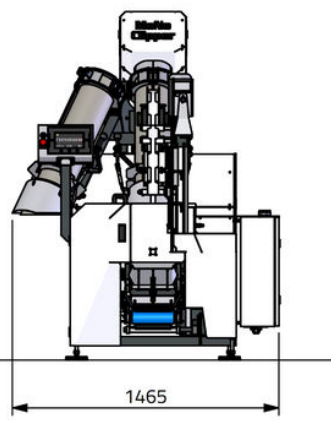
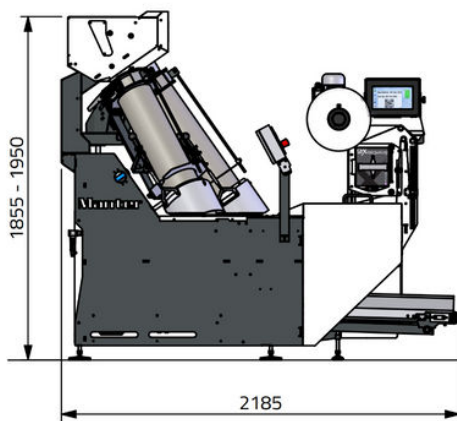

Manter International B.V.

P.O. Box 2124 NL
7801 CC Emmen
The Netherlands

Office

Phileas Foggstraat 66
7825 AL Emmen
The Netherlands

Contact

+31 591 626300
sales@manter.com
www.manter.com

