

M1 SF

Weighing machine



NL

- Bandweger voor het wegen van gesorteerd product.
- Productvriendelijk voor hard fruit zoals bijvoorbeeld appels en peren.
- Te combineren met allerlei soorten verpakkingsmachines.
- Gemaakt van RVS en aluminium.
- Eenvoudige bediening middels touchscreen.

DE

- Bandwaage zum Wiegen sortierter Produkte.
- Produktfreundlich für harte Früchte wie Äpfel und Birnen.
- Zu kombinieren mit verschiedenen Verpackungsmaschinen.
- Aus Edelstahl und Aluminium.
- Einfache Bedienung mittels Touchscreen.

EN

- Belt weigher for weighing sorted product.
- Product-friendly for hard fruit such as apples and pears.
- Combinations with many packaging machines possible.
- Made of stainless steel and aluminum.
- User-friendly touchscreen.



M1 SF

Weighing machine

NL Specificaties:	DE Spezifikationen:	EN Specifications:	
Weegbereik:	Wiegebereich:	Weighing range:	0.5 - 5 kg*
Capaciteit bij 1kg tot:	Leistung bei 1kg bis zu:	Capacity at 1kg up to:	15 bpm*
IP-beschermingsklasse	IP-Schutzklasse	IP-rating	IP54
Lucht consumptie: (geconditioneerde droge lucht)	Luftverbrauch: (konditionierte trockene Luft)	Air consumption: (conditioned dry air)	25 L/min
Voedingsspanning:	Spannungsdaten:	Supply voltage	3x 400V/50Hz+N+GND
Stroomverbruik:	Anschlusswert:	Powerconsumption:	1.2 kW
Gewicht van de machine:	Gewicht der Maschine:	Weight of the machine:	175 kg

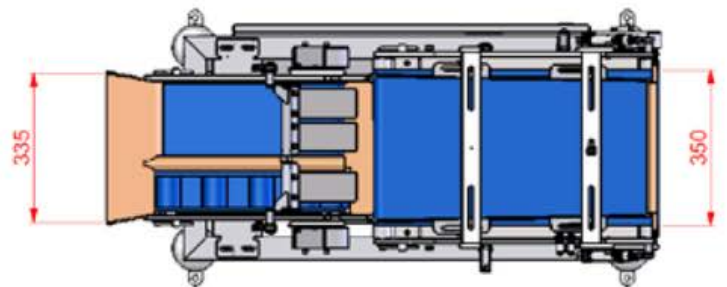
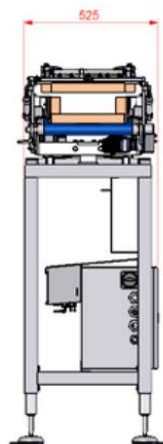
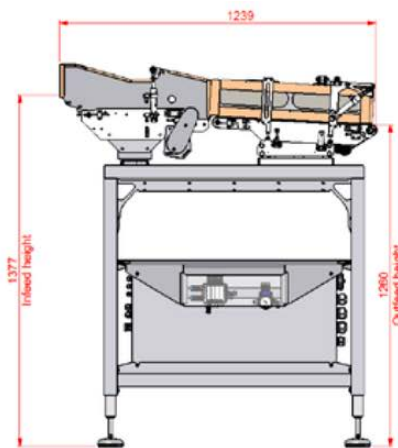

*Afhankelijk van product en afvoersysteem.
Abhängig von Produkt und Entladesystem.
Depends on product and discharge system.

Manter International B.V.

P.O. Box 2124 NL
7801 CC Emmen
The Netherlands

Office

Phileas Foggstraat
66 7825 AL Emmen
The Netherlands

Contact

+31 591 626300
sales@manter.com
www.manter.com

